

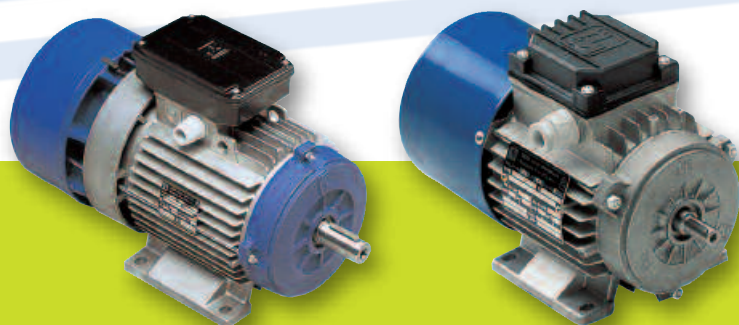

# Brake Motors

General Catalogue



GENERAL INFORMATION	4
PRODUCT RANGE: POWER AND POLES	5
MOTOR DESIGNATION	6
STANDARDS AND APPROVALS	7
CE MARK - UL AND CSA STANDARDS - BIS CERTIFICATION	7
CCC DECLARATION - EAC DECLARATION	7
MOTOR IDENTIFICATION NAMEPLATE	8
TOLERANCES - STANDARD AND SPECIAL FLANGES	9
TYPE OF COSTRUCTIONS AND MOUNTING ARRANGEMENTS	10
ENCLOSURE RATINGS	11
BEARINGS	12
RECTIFIERS	13
MOTOR VOLTAGE AND FREQUENCY SUPPLY	14
OPERATING AT 60 HZ	14
SERVICE DUTY TYPES	15
MOTOR RUNNING ON INVERTER	16
BALANCING - NOISE - MANUAL BRAKE RELEASE AND SHAFT ROTATION	17
TEMPERATURE, ALTITUDE, HUMIDITY	18
PROTECTION DEVICES	19
EFFICENCY	20
MOTORS FOR USA AND CANADA	22
TEST AND CONTROL DOCUMENTS	23
PAINTING	23
BA SERIES GENERAL CHARACTERISTICS	25
AIR GAP ADJUSTMENT	26
BRAKE TORQUE ADJUSTMENT	26
PERMISSIBLE START FREQUENCY AT LOAD	26
BRAKE COIL WIRING DIAGRAM	26
BRAKE TORQUE AND BRAKE SPRINGS COMPRESSION	27
TECHNICAL DATA SINGLE SPEED MOTORS SINGLE WINDING (2, 4 POLES)	28
TECHNICAL DATA SINGLE SPEED MOTORS SINGLE WINDING (6, 8 POLES)	29
TECHNICAL DATA TWO SPEED MOTORS SINGLE WINDING (2/4 POLES)	30
TECHNICAL DATA TWO SPEED MOTORS SINGLE WINDING (4/8 POLES)	31
TECHNICAL DATA TWO SPEED MOTORS TWO WINDINGS (2/6 POLES)	32
TECHNICAL DATA TWO SPEED MOTORS TWO WINDINGS (2/8 POLES)	33
TECHNICAL DATA TWO SPEED MOTORS TWO WINDINGS (4/6 POLES)	34
TECHNICAL DATA TWO SPEED MOTORS TWO WINDINGS (4/12 POLES)	35

36	TECHNICAL DATA TWO SPEED MOTORS TWO WINDINGS (2/12 POLES)
36	HOISTING MOTORS 4/16 POLES
37	STARTING AND BRAKING TIME
37	BRAKE DISC LININGS WEAR
38	BA-BAX AND BAH-BAHX SERIES DIMENSIONS
41	BM SERIES GENERAL CHARACTERISTICS
42	BM SERIES BRAKE GROUP
42	AIR GAP ADJUSTMENT
42	PERMISSIBLE STARTING FREQUENCY WITH LOAD
43	RECTIFIERS WIRING DIAGRAM AND BRAKE REACTION TIME
43	BRAKING TIME CALCULATION
44	TECHNICAL DATA SINGLE SPEED MOTORS SINGLE WINDING (2, 4 POLES)
45	TECHNICAL DATA SINGLE SPEED MOTORS SINGLE WINDING (6, 8 POLES)
46	TECHNICAL DATA TWO SPEED MOTORS SINGLE WINDING (2/4, 4/8 POLES)
47	TECHNICAL DATA TWO SPEED MOTORS TWO WINDINGS (2/6, 2/8 POLES)
48	TECHNICAL DATA TWO SPEED MOTORS TWO WINDINGS (4/6, 4/12 POLES)
49	BM-BMX SERIES DIMENSIONS
50	TRAVERSE MOTORS WITH PROGRESSIVE START AND STOP (PV SERIES)
52	BAH SERIES
54	HOIST MOTORS (BAPK SERIES)
54	PREMIUM BRAKE TORQUE MOTORS (BAF SERIES)
55	FORCED COOLING MOTORS (SV SERIES)
56	BUILT-IN ENCODER MOTORS (E SERIES)
56	BAE-BAHE SERIES DIMENSIONS
57	BMEAV SERIES DIMENSIONS
59	R SERIES
61	BUILT-IN INVERTER MOTORS
62	MOTORS FOR WIND GENERATION
62	MOTORS FOR AUTOMATIC INDUSTRIAL DOORS
63	DOUBLE BRAKE MOTORS (BMBM SERIES)
64	BMBM SERIES DIMENSIONS
65	INDIA
65	CHINA
65	RUSSIA - AUSTRALIA AND NEW ZEALAND
66	PACKAGING - TERMS AND SALE CONDITIONS AND WARRANTY
67	SPECIAL FEATURES AND OPTIONS
68	SPARE PARTS BA SERIES
70	SPARE PARTS BM SERIES

## general information

MGM brake motors are asynchronous three-phase totally enclosed fan cooled motors (TEFC). The motor brakes in case of power supply failure. The braking action is always obtained through a very quick and precise stop and it guarantees a safe and prompt intervention in case of power failure.

The braking action is obtained without shaft axial sliding and it provides equal braking torque in both directions of rotation. MGM brake motors are particularly suitable for hoist and traverse machines, tooling machinery, automatic and transfer machinery in textile, ceramic and packing fields and in all those situations where precision and quick-

ness in braking are required. MGM brake motors are designed and assembled as real brake motors. The perfect engineering and assembling combined with a strong and safe brake, make these motors very reliable.

As standard, on the IM B3 mounting (foot mounted), feet are integrated in the frame (they are not attached to the frame) making the motor very sturdy. This feature is very important on those brake motor applications where the stress during start/stop is very high.

The brake disc lining material is asbestos free with high friction coefficient and very long lasting. The motors are provided with

the IP 54 enclosure rating and insulation class F. On request they can be provided with the IP 55 or IP 56 enclosure ratings and with insulation class H. All MGM motors are designed for inverter duty. On request it is possible to supply the motor with an encoder fitted on the shaft's non drive end (NDE), or to have the shaft predisposed for encoder fitting. For further information please refer to the encoder series section. MGM brake motors series are: BA and BM.

### BA series

The BA series consists of three phase, asynchronous brake motors totally enclosed fan cooled (TEFC). The BA series range starts from 71 up to 315 frame size. As standard, the brake power supply is AC 3-phase. On request DC brake can be provided with a rectifier integrated in the terminal box. The rectifier is provided with an over-voltage protection device. All BA series motors are provided with manual brake release. The BA series cooling fan is fitted between the motor and the braking assembly. The brake moving element and the brake coil have a laminated magnetic nucleus to reduce losses and to allow very fast brake.

BA series main features are a very quick braking action, both in releasing and braking operation, a high brake torque, a constant braking time and a very high number of start/stop cycles also under severe applications.

### BM series

The BM series consists of three phase, asynchronous brake motors totally enclosed fan cooled (TEFC). The BM series range starts from 56 up to 225 frame size. As standard the brake power supply is DC 1-phase with a rectifier integrated in the terminal box. The rectifier is provided with an over-voltage protection device. The cooling fan is fitted at non-drive shaft end.

BM series main features are a low braking noise, a gradual acceleration during the motor start and stop and reduced overall dimensions.

The BA and BM series are also available in the following main versions:

- PV** (BAPV, BMPV): with flywheel that allow progressive start and stop, particularly suitable for traverse application
- F** (BAF): with double brake disc and extremely high brake torque
- AV-SV** with forced cooling (BMAV with axial forced cooling, BASV with double radial forced cooling)
- BM** (BMBM) with double brake particularly suitable to be used in TV-cine studios and theatres stages
- E** (BAE, BME) with built-in encoder
- K** (BAPK, BAK) with K brake disc for hoisting applications

The table below shows the brake motors production range of BM, BA and BAH motor series.

Motor type	Series	2 pole kW	4 pole kW	6 pole kW	8 pole kW	2/4 pole kW	4/8 pole kW	2/6 pole kW	2/8 pole kW	4/6 pole kW	4/12 pole kW S3 40%	2/12 pole kW S3 40%	4/16 pole kW S4 40% - 4 pole S4 25% - 16 pole
56 A	BM	0.09	0.06	0.04									
56 B	BM	0.12	0.09	0.06									
63 A	BM	0.18	0.12										
63 B	BM	0.25	0.18			0.22/0.15							
63 C	BM	0.37	0.22	0.09		0.26/0.17			0.18/0.04				
63 D	BM	0.45	0.30	0.12	0.07								
71 A	BM BA	0.37	0.25	0.18	0.08	0.25/0.18	0.13/0.07						
71 B	BM BA	0.55	0.37	0.25	0.11	0.37/0.25	0.18/0.09	0.25/0.08	0.25/0.06				
71 C	BM BA	0.75	0.55				0.22/0.12	0.35/0.1	0.35/0.07	0.18/0.11			
71 D	BM BA		0.65										
80 A	BM BA	0.75	0.55	0.37	0.18	0.65/0.45	0.25/0.18	0.37/0.12	0.37/0.09	0.25/0.18	0.25/0.05		
80 B	BM BA	1.1	0.75	0.55	0.25	0.88/0.62	0.37/0.25	0.55/0.18	0.55/0.12	0.37/0.25	0.37/0.07	0.45/0.07	
80 C	BM BA		0.90										
90 SA	BM BA	1.5	1.10	0.75	0.37		0.75/0.37	0.9/0.3		0.55/0.37	0.4/0.13	0.75/0.11	
90 SB	BM BA					1.3/0.9			0.75/0.18				
90 LA	BM BA	2.2	1.50	1.10	0.55	1.8/1.2		1.2/0.4	1.1/0.25		0.55/0.18	1.1/0.15	
90 LB	BM BA		1.85	1.30	0.65	2.2/1.5	1.1/0.6	1.4/0.5	1.3/0.3	0.75/0.55	0.75/0.22		
90 LC	BM BA		2.2										
100 LA	BM BA	3.0	2.2	1.50	0.75	2.2/1.5		1.6/0.6	1.6/0.4	1.1/0.8	0.9/0.25		
100 LB	BM BA		3.0	1.85	1.1	3.1/2.3	1.6/0.9	2.2/0.8	2.2/0.5	1.5/1.0	1.1/0.35	1.85/0.25	
112 MB	BM BA	4.0	4.0	2.2	1.5	4.5/3.3	2.2/1.2	3.0/1.0	3.0/0.8	2.0/1.3	1.5/0.45	3.0/0.45	
112 MC	BM BA	5.5	5.5										
132 SA	BM BA	5.5									2.5/0.8		
132 SB	BM BA	7.5	5.5	3.0	2.2	5.0/4.5	3.0/2.0	4.0/1.3	4.0/1.1	2.2/1.5		4.0/0.65	
132 MA	BM BA	9.2	7.5	4.0		6.0/5.0	4.0/2.7	5.5/1.8	5.5/1.5	3.0/2.2	3.0/1.0	5.5/0.9	2.8/0.7
132 MB	BM BA	11.0	9.2	5.5	3.0	7.5/6.0	6.0/4.0	7.0/2.2	7.0/1.8	3.7/2.5	4.0/1.3	7.0/1.1	4.0/1.1
132 MC	BM BA		11.0										
160 MA	BM BA	11.0	9.2		4.0	9.5/8.0							5.5/1.3
160 MB	BM BA	15.0	11.0	7.5	5.5	11.0/9.0	6.5/4.5	8.0/2.5	8.0/2.2	5.5/3.7	4.8/1.6	8.0/1.3	7.3/1.8
160 LA	BM BA	18.5	15.0	9.2	7.5	13.0/11.0	9.5/6.0	11.0/3.6	11.0/3.0			11.0/1.8	
160 LB	BM BA			11.0						7.5/5.0	7.3/2.4		10.0/2.5
180 LA	BM BA	22.0	18.5			17.0/14.0	11.0/8.0			11.0/7.5			13.2/3.0
180 LB	BM BA		22.0	15.0	11.0	20.5/17.0	14.0/9.0	16.0/6.5	16.0/4.0	13.0/8.8		16.0/2.6	
200 LA	BM BA	30.0		18.5	15.0		18.0/11.0						
200 LB	BM BA	37.0	30.0	22.0		24.0/20.0	21.0/13.0		18.5/4.5	15.0/10.5			16.0/4.0
225 S	BM BAH		37.0			37.0/30.0	30.0/18.0		24.0/6.0				19.0/4.8
225 M	BM BAH		45.0	30.0	22.0	45.0/35.0	35.0/25.0		30.0/7.5				24.0/6.0
225 MC	BM BAH		55.0	37.0									30.0/7.5
250 M	BAH		55.0	37.0	30.0		42.0/30.0						30.0/7.5
280 S	BAH		75.0	45.0	37.0		45.0/33.0						45.0/10.0
280 M	BAH		90.0	55.0	45.0		55.0/40.0						55.0/12.0
315 S	BAH		110.0	75.0	55.0								
315 M	BAH		132.0	90.0	75.0		86.0/58.0						

Note: all motors indicated in the table above can also be produced as standard asynchronous three phase motors without brake (SMX or SM Series)

The following technical characteristics are used to correctly identify MGM motors:

<b>Series</b>	BA, BM <b>1</b>	example: <b>BA</b>
<b>Frame size</b>	56 - 315 mm	example: <b>71</b>
<b>Power and poles</b>	0.04 - 132 kW 2 4 6 8 2/4 4/8 2/6 2/8 4/6 4/12 pole <b>2</b>	example: <b>0.37 kW 4 Pole</b> or B 4 (see technical data)
<b>Mounting</b>	see mounting section	example: <b>IM B5</b>
<b>Voltage and frequency</b>	according to customer request	example: <b>230/400V 50 Hz</b>
<b>Brake supply</b>	AC or DC <b>3</b> single or double terminal board box <b>4</b>	example: <b>AC brake coil double terminal board box</b> for separate brake supply
<b>Insulation class</b>	F or H	example: <b>class F</b>
<b>Enclosure</b>	IP54, IP55, IP56	example: <b>IP 54</b>

It is necessary to indicate any special features or options not supplied as standard (see page 67), such as reduced diameter flanges, thermal protectors, tropical environment execution, etc. Unless otherwise specified, the brake supply voltage is the same as the motor voltage. Unless otherwise specified, the DC brake voltage supply is 230V 50/60 Hz.

**1**

The BM and BA series are also available in the versions BMPV, BAPV with soft start and stop suitable for traversing, and the version BMSV, BASV with forced cooling fan. The BA series is also available in the version BAF, with double brake disc and premium brake torque.

**2**

In two speed motors, the model number is followed by the letter D on motors with Dahlander winding, and by the letters DA on motors incorporating two separate windings (i.e. BADA 71 B 2/8).

**3**

BA series motors are available with both DC and AC brakes while BM series motors are available with DC brakes only. Brake Motors equipped with a DC brake and a power supply higher than 24V are supplied with a suitable rectifier located inside the terminal box.

**4**

Single speed motors can be provided with a single terminal box with the motor and brake power terminals connected in parallel, or with a double terminal board, having the supply separated from the motor. Unless otherwise specified, single speed motors up to 90 frame size are provided with just one terminal board. Motors with frame size 100 and above are provided as standard feature with a double terminal board box. On two speed motors, the motor power supply is always separate from the brake power supply. On single speed motors with separate brake power supply a double terminal board box has to be provided. A double terminal board box also has to be provided on motors with the following options or auxiliary devices: thermo protectors (PTO), thermistors (PTC), anti-condensation heaters, forced cooling, IP 56 enclosure, EMI filters, DC brake with brake power supply higher than 254V, brake voltage different from motor voltage, motor voltage 400/690V 50Hz, encoder, microswitch, terminal box on side.

Example BA 71 B4, 230/400V 50 Hz, class F, IP 54, IM B5, AC brake coil, double terminal board box

Description	IEC	GENELEC
Ratings and performance	IEC 60034-1	EN 60034-1
Efficiency classes	IEC 60034-30-1	EN 60034-30-1
Standard test methods for determining losses and efficiency	IEC 60034-2-1	EN 60034-2-1
Cooling methods for rotating electrical machines	IEC 60034-6	EN 60034-6
Terminal markings and direction of rotation of rotating machines	IEC 60034-8	EN 60034-8
Characteristics of mountings and types of installation	IEC 60034-7	EN 60034-7
Starting performance of asynchronous three phase single speed cage motors	IEC 60034-12	EN 60034-12
Classification of protection degree of rotating electrical machines	IEC 60034-5	EN 60034-5
Mechanical vibrations of machines with shaft height 56 mm and higher. Measurement, assessment and limits of vibration severity	IEC 60034-14	EN 60034-14
Fixing dimensions and rating powers	IEC 60072	EN 50347
Noise limits	IEC 60034-9	EN 60034-9

### CE mark

MGM brake motors have the **CE** mark on the nameplate to indicate the conformity to the requirements of the Union harmonization legislations 2014/35/EU “Low Voltage Directive” and 2014/30/EU “Electromagnetic Compatibility”.

### UL and CSA standards

On request MGM motors can be provided with cCSAus approval in conformity with the requirements of the standards UL 1004-1 “Electric motors” and CSA C 22.2 No. 100 “Motors and generators” for the North American market. The approved motors show the  mark on the nameplate. For more info please see the related paragraph (Motors for Usa and Canada).

### BIS certification

MGM motors can be provided, on request, with BIS certification (standard IS 12615:2018) that is the compulsory certification in India. Certified motors show the  mark on the nameplate. For more info please see the related paragraph (India).

### CCC declaration

On request MGM motors can be provided with CCC (China Compulsory Certification) declaration for the Chinese market. The approved motors show the  mark on the nameplate. For more info please see the related paragraph (China).

### EAC declaration

On request MGM motors can be provided with EAC declaration for the Eurasian Custom Union countries (Russia, Belarus, Kazakhstan). For more info please contact MGM.

# motor identification nameplate

Every motor is provided with an identifying nameplate, on which specific motor information is given. Motor nameplates are shown below with motor data and explanatory notes. The nameplate shown on the left is used for single speed motors while the nameplate on the right is used for two speed motors.

M.G.M. motori elettrici S.p.A.  
Serravalle P.se (PT) ITALY  
http://www.mgmrestop.com

Type <sup>5</sup> Mot. <sup>34</sup> ~ <sup>1</sup> IP <sup>2</sup> Ins.Cl. <sup>3</sup> IM <sup>28</sup> Kg <sup>4</sup>  
Brake max <sup>7</sup> Nm Vb= <sup>9</sup> Ib= <sup>8</sup> A

Hz	kW	Cos φ	RPM	V Δ	I Δ	VY	IY	Eff
50	<sup>10</sup>	<sup>11</sup>	<sup>12</sup>	<sup>13</sup>	<sup>14</sup>	<sup>15</sup>	<sup>16</sup>	<sup>30</sup>
60	<sup>17</sup>	<sup>18</sup>	<sup>19</sup>	<sup>20</sup>	<sup>21</sup>	<sup>22</sup>	<sup>23</sup>	<sup>31</sup>

Made in Italy

M.G.M. motori elettrici S.p.A.  
Serravalle P.se (PT) ITALY  
http://www.mgmrestop.com

Type <sup>5</sup> Mot. <sup>34</sup> ~ <sup>1</sup> IP <sup>2</sup> Ins.Cl. <sup>3</sup> IM <sup>28</sup> Kg <sup>4</sup>  
Brake max <sup>7</sup> Nm Vb= <sup>9</sup> Ib= <sup>8</sup> A

Hz	V	I	kW	Cos φ	RPM
50	<sup>24</sup>	<sup>25</sup>	<sup>10</sup>	<sup>11</sup>	<sup>12</sup>
60	<sup>26</sup>	<sup>27</sup>	<sup>17</sup>	<sup>18</sup>	<sup>19</sup>

Made in Italy

- 1 Duty type
- 2 Protection degree
- 3 Insulation Class, the letters TR following the insulation class indicate tropicalized treatment
- 4 Weight (Kg)
- 5 Motor type Designation
- 6 Serial number
- 7 Maximum Static Brake Torque obtainable with proper regulation of the springs (Nm)
- 8 Brake current (A)
- 9 Brake Voltage Supply (V). On brake motors with AC brake, the symbol "Vb = Vm" indicates that the motor and brake have the same voltage supply. For the motor with DC brake the indication 1~230V or 1~400V represent the AC side single phase input voltage to the rectifier (230V or 400V)
- 10 Rated Power (kW) at 50 Hz
- 11 Power Factor at 50 Hz
- 12 Motor Speed (RPM) at 50 Hz
- 13 Motor Voltage Supply at 50 Hz, Delta connected
- 14 Motor Amps at 50 Hz, Delta connected
- 15 Motor Voltage Supply at 50 Hz, Star connected
- 16 Motor Amps at 50 Hz, Star connected
- 17 Rated Power (kW) at 60 Hz
- 18 Power Factor at 60 Hz
- 19 Motor Speed (RPM) at 60 Hz
- 20 Motor Voltage Supply at 60 Hz, Delta connected
- 21 Motor Amps at 60 Hz, Delta connected
- 22 Motor Voltage Supply at 60 Hz, Star connected
- 23 Motor Amps at 60 Hz, Star connected
- 24 Motor voltage supply at 50 Hz
- 25 Motor Amps at 50 Hz
- 26 Motor voltage supply at 60 Hz
- 27 Motor Amps at 60 Hz
- 28 Mounting
- 29 For motors with forced cooling fans, the fan voltage supply is shown in this location, preceded by the letters "VENT". The letters "TP" indicate the presence of bimetallic thermal protectors, "TM" indicate thermistors, and "SCALD" indicates anti-condensation heaters, all followed by the voltage supply
- 30 Efficiency and efficiency class at 50Hz
- 31 Efficiency and efficiency class at 60Hz
- 32 Certification marks (UL, CCC, etc.)
- 33 If the letters "DM" appear in this location, it means that the motor is supplied with a double terminal board box for a separate brake feeding
- 34 Motor phases number (3 = three phase; 1 = single phase)

Note: on motor nameplates with special execution additional information or information placed in different fields can be present.



## Electromechanical characteristics tolerances

The table below, describes the electromechanical tolerances concerning electric motors, according to the EN 60034-1 standard.

Parameter	Tolerance
Efficiency $\eta$	-0.15 (1 - $\eta$ ) Rated power $\leq$ 150 kW
Power factor $\cos\phi$	-(1 - $\cos\phi$ ) / 6 min 0,02 - max 0,07
Slip	$\pm 30\%$ Rated power < 1 kW $\pm 20\%$ Rated power $\geq$ 1 kW
Locked rotor current	+20%
Moment of Inertia	$\pm 10\%$ the guaranteed value
Locked rotor torque	-15% the guaranteed value +25% the guaranteed value (upon request it is possible to exceed the +25% value)

## Mechanical tolerances

The table below describes the mechanical tolerances in accordance with the IEC 72 standard.

Characteristic	Tolerance
Shaft height	-0,5 mm
Flange spigot	j6 for motors with shaft heights $\leq$ 160 mm h6 for motors with shaft heights > 180 mm
Shaft end diameter	j6 $\varnothing$ from 9 mm up to 28 mm k6 $\varnothing$ from 38 mm up to 48 mm m6 $\varnothing$ from 55 mm up to 75 mm

## Standard and special flanges

The table below shows the dimensions of the standard flanges and of the special ones available along with the shaft dimensions. NEMA flanges and shafts are available on request.

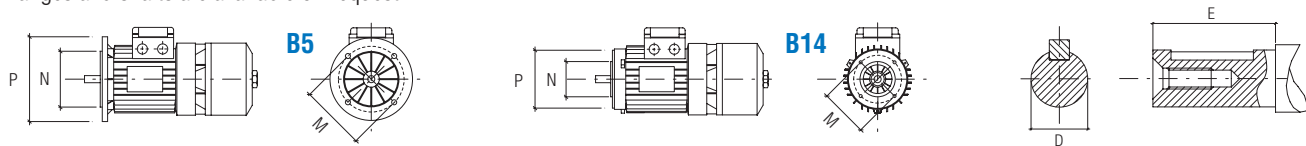

Motor frame size	Shaft drive end dimensions (DxE) (mm)	Flange type	Flange dimensions (P/M/N) (mm)
IEC 56	9x20	B5 (standard)	120/100/80
IEC 56	9x20	B14 (standard)	80/65/50
IEC 63	11x23	B5 (standard)	140/115/95
IEC 63	11x23	B14 (standard)	90/75/60
IEC 63	11x23	B14-R (56)	(80) 90/65/50***
IEC 71	14x30	B5 (standard)	160/130/110
IEC 71	14x30	B5-R (56)*	120/100/80
IEC 71	14x30	B5-R/M (63)*	140/115/95
IEC 71	14x30	B5-M	200/165/130
IEC 71	14x30	B14 (standard)	105/85/70
IEC 71	14x30	B14-R	(90) 105/75/60***
IEC 80	19x40	B5 (standard)	200/165/130
IEC 80	19x40	B5-R	160/130/110
IEC 80	19x40	B14	120/100/80
IEC 80	19x40	B14-R	(105) 120/85/70***
IEC 90	24x50	B5 (standard)	200/165/130
IEC 90	24x50	B5-R	160/130/110
IEC 90	24x50	B14 (standard)	140/115/95
IEC 90	24x50	B14-R	(120) 140/100/80***
IEC 100	28x60	B5 (standard)	250/215/180
IEC 100	28x60	B5-R**	200/165/130
IEC 100	28x60	B14 (standard)	160/130/110
IEC 112	28x60	B5 (standard)	250/215/180
IEC 112	28x60	B14 (standard)	160/130/110
IEC 132	38x80	B5 (standard)	300/265/230
IEC 132	38x80	B5-R	250/215/180
IEC 132	38x80	B14 (standard)	200/165/130
IEC 160	42x110	B5 (standard)	350/300/250
IEC 180	48x110	B5 (standard)	350/300/250
IEC 200	55x110	B5 (standard)	400/350/300
IEC 225 (4-6-8 poles)	60x140	B5 (standard)	450/400/350
IEC 250 (4-6-8 poles)	65x140	B5 (standard)	550/500/450
IEC 280 (4-6-8 poles)	75x140	B5 (standard)	550/500/450
IEC 315 (4-6-8 poles)	80x140	B5 (standard)	660/600/550

Notes: \* This type of flange requires a special shaft therefore it isn't interchangeable with the standard one. This flange increases the motor length (Q) by 25mm.

\*\* This type of flange requires a special bearing while the shaft remains the standard one.

\*\*\* The difference between the dimension of the reduced flange and the standard one (in brackets) doesn't affect the correct motor assembly.

For 2 poles motors 225 frame size and above please contact MGM.

## type of construction and mounting

The table below shows the most important types of mounting arrangements according to IEC 34-7 (EN 60034-7) standard. Two systems of classification are provided: code 1 (the alpha-numeric designation) and code 2 (the numeric designation).

### Horizontal shaft mountings

**IM B3**

**IM 1001**

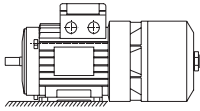

Foot mounted motor, feet down.

**IM B5**

**IM 3001**

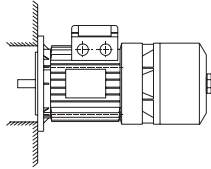

Flange mounted on D-End side.

**IM B35**

**IM 2001**

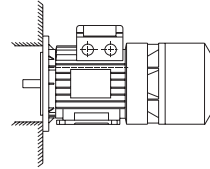

Foot and flange mounted motor.

**IM B6**

**IM 1051**

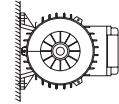

Foot mounted motor. Feet left (viewed from D-End).

**IM B7**

**IM 1061**

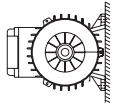

Foot mounted motor. Feet right (viewed from D-End).

**IM B8**

**IM 1071**

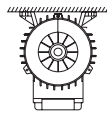

Foot mounted motor. Feet up (viewed from D-End).

**IM B14**

**IM 3601**

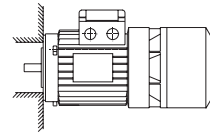

Face mounted. Flange with threaded holes and spigot.

**IM B34**

**IM 2101**

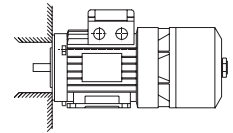

Face and foot mounted. Flange with threaded holes and spigot.

### Vertical shaft mountings

**IM V1**

**IM 3011**

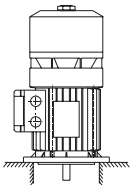

Flange mounted. Shaft down.

**IM V15**

**IM 2011**

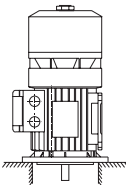

Foot and flange mounted motor. Shaft down.

**IM V3**

**IM 3031**

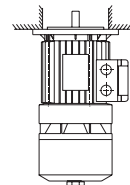

Flange mounted. Shaft up.

**IM V36**

**IM 2031**

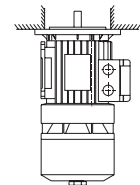

Foot and flange mounted motor. Shaft up.

**IM V5**

**IM 1011**

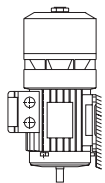

Foot mount. Shaft down.

**IM V6**

**IM 1031**

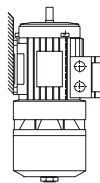

Foot mount. Shaft up.

**IM V18**

**IM 3611**

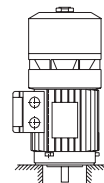

Face mount. Shaft down. Flange with threaded holes and spigot.

**IM V19**

**IM 3631**

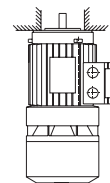

Face mount. Shaft up. Flange with threaded holes and spigot.

Notes:

for information about the classifications of other types of construction and mounting please contact MGM.

The enclosure rating of the motor has to be suitable for the environment conditions the motor operates in. According to the IEC34-5 (EN 60034-5) standard the designation of the protection degree is expressed by means of a symbol made up of two letters (IP) followed by a two digit number. The first digit indicates the protection degree provided by the motor enclosure in contact with parts in motion, electrically energized, or against the penetration of foreign bodies. The second digit indicates the protection degree of the motor enclosure against damages caused by the liquid infiltration.

IP First digit Second digit

### First digit

- 0** No protection.
- 1** The machine is protected against the penetration of solid bodies greater than 50 mm in diameter (for example, protection against the accidental touch of a hand).
- 2** The machine is protected against the penetration of solid bodies greater than 12 mm in diameter.
- 3** The machine is protected against the penetration of solid bodies greater than 2.5 mm in diameter.
- 4** The machine is protected against the penetration of solid bodies greater than 1mm in diameter.
- 5** The machine is protected against the penetration of dust. The penetration is not completely avoided, but should not compromise the good functioning of the machine.
- 6** Dust tight machine.

### Second digit

- 0** No protection.
- 1** Vertical dropping of water on the machine will not result in damaging effects.
- 2** Vertical dropping of water on the machine will not result in damaging effects when the machine is not inclined more than 15° from its normal position.
- 3** Water or rain dropping on the machine at an angle up to 60° will not result in damaging effects.
- 4** Water spraying on the machine from any angle will not result in damaging effects to the machine.
- 5** Water jets on the machine from any angle will not result in damaging effects to the machine.
- 6** Waves of water will not result in damaging effects to the machine.
- 7** Immersing the machine in water under specific conditions of pressure and time will not cause the ingress of a damaging quantity of water.
- 8** Immersing the machine permanently in water under conditions of pressure and time given by the manufacturer will not result in damaging effects.

MGM brake motors come with standard IP54 enclosure rating. On request, motors can be provided with IP55, IP56, IP65 and IP66 enclosure rating. BAH series motors come as standard with a IP55 protection degree and on request with a IP56 or IP66.

For use in standard industrial environments IP54 is sufficient. For outdoor applications or for application that involve contact with water, protection degree IP55 or IP56 is advisable; it's however recommended to adopt appropriate additional protections.

During installation check the proper tightening of the cable gland and, if possible, provide the cable entry with curving from bottom up. For outdoor vertical mounting with shaft down a rain roof (for BM series) and a special brake cover (for BA series) are available on request.

All MGM brake motors are equipped with double seal ball bearings. The bearings are lubricated for life with a considerable grease reserve, the seals are made of synthetic rubber resistant to oil and to wear. On MGM brake motors belonging to BAX and BMX series can be installed bearings with a "Z" shield instead of a "2RS" one.

Frame size	Bearing type	
	Drive end (D)	Non-drive end (ND)
56	6201 - 2Z	6201 - 2Z
63	6202 - 2RS1	6202 - 2RS1
71	6203 - 2RS1	6203 - 2RS1
80	6204 - 2RS1	6204 - 2RS1
90	6205 - 2RS1	6205 - 2RS1
100	6206 - 2RS1	6206 - 2RS1
112	6306 - 2RS1	6306 - 2RS1
132	6308 - 2RS1	6308 - 2RS1
160	6309 - 2RS1	6309 - 2RS1
180	6310 - 2RS1	6310 - 2RS1
200	6312 - 2RS1	6310 - 2RS1
225	6214 - 2RS1	6312 - 2RS1
250	6316 - 2RS1	6314 - 2RS1
280	6316 - 2RS1	6314 - 2RS1
315	6318 - 2RS*	6318 - 2RS*

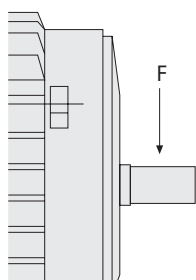

The nominal bearings lifetime is expressed in working hours reached or exceeded by 90% of the same bearings under certain test conditions.

The key parameters that affect bearings life are the load applied on the bearing, the rotation speed and the operating temperature. The values in the table are referred to the case in which there's only radial load.

It also assumes that the radial force doesn't change in intensity and direction. The point of force application is the center line of the shaft end (as shown) with the motor in horizontal position. Values in the table show the maximum applicable force on the shaft to obtain the duration described in the table. The force is stated in Newtons (N).

\* For motors with shaft height 315, contact MGM to receive specific information according to the type of mounted bearing.

Frame size	20000 hours				40000 hours			
	2 pole	4 pole	6 pole	8 pole	2 pole	4 pole	6 pole	8 pole
56	320	410	470	520	260	320	370	410
63	410	520	600	650	330	410	470	520
71	500	630	720	800	400	500	570	630
80	660	840	950	1200	500	660	750	840
90	720	900	1000	1300	550	720	820	900
100	1000	1250	1400	1800	790	1000	1100	1250
112	1450	1850	2100	2650	1150	1450	1650	1850
132	2150	2700	3100	3950	1700	2150	2450	2700
160	2700	3400	3900	4900	2100	2700	3050	3400
180	3250	4100	4700	5980	2600	3250	3750	4100
200	4300	5450	6250	6850	3400	4300	4950	5450
225		5240	5990	6630		4150	4750	5260
250		10390	12400	13100		7950	9530	10400
280		10390	12400	13100		7950	9530	10400

The brake motors belonging to the BA series with the DC brake and all BM series motors (except those with voltage lower than 42Vdc) are equipped with a rectifier located inside the terminal box. These rectifiers can be half wave or full wave type according to the voltage supply (AC side) and to the required brake coil voltage (DC side). Rectifiers come standard with over-voltage protection devices. Rectifiers are provided with two connection options (fig. 1-diagram A and B) for fast and slow brake reaction time. Rectifiers can be provided in C type (integrated in the terminal box cover-fig. 2), Q type (with loose wires-fig. 3), or M type (with clamp terminals-fig. 4). The rectifier resin colour identifies the rectifier rated voltage as indicated in the table below.

Resin colour	Applicable voltage ( $V_{ac}$ )	Output voltage ( $V_{dc}$ )	Standard values ( $V_{ac} \rightarrow V_{dc}$ )
Blue	200-265	$0,45 * V_{ac}$	230 → 103
Yellow	360-440	$0,45 * V_{ac}$	400 → 180
Green	90-130	$0,9 * V_{ac}$	110 → 100

$V_{ac}$  refers to the input AC (rms value) voltage while  $V_{dc}$  refers to the mean value of the output DC voltage.

The following models are also available upon request:

**Model R**

This type of rectifier is recommended when a faster brake engaging time is required and if an external contact on the DC circuit isn't available. A relay, integrated in the rectifier circuit, allows in an independent way to open the circuit on the DC side.

**Model P**

This type of rectifier is recommended when a fast brake release and/or a higher braking torque is needed. This rectifier is designed in such a way to provide initially twice the rated output voltage allowing the brake coil to quickly attract the moving element.

fig. 1

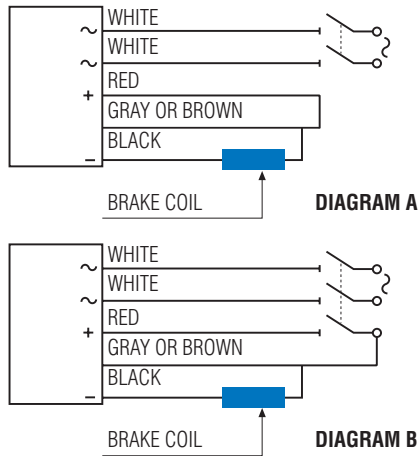

fig. 2

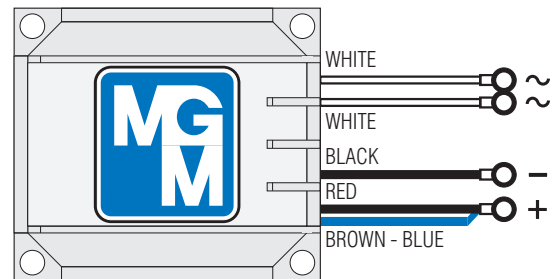

fig. 3

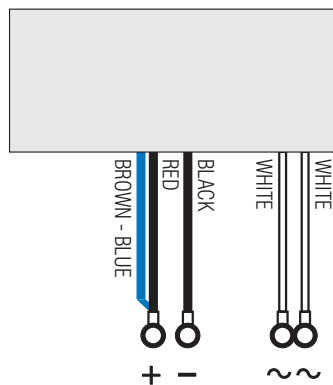
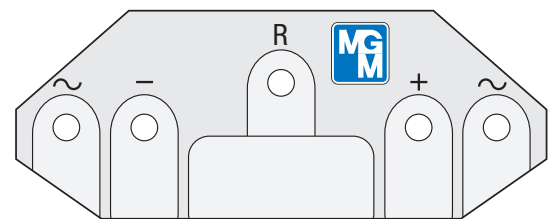

fig. 4



## motor voltage and frequency supply

MGM motors are provided with a standard voltage rating of 230/400V±10% 50 Hz (IEC 38, CENELEC HD 472, CEI 8-6) “European voltage”. On request they can be provided with different operating voltages. The operating voltages at 50Hz and 60Hz are clearly indicated on the motor nameplate (see motor nameplate section). MGM motors are suitable to work within a voltage variation of 10% on the nameplate voltage. The available rated voltages are shown in the table below under “Nameplate voltage” at 50 Hz and 60 Hz, while the corresponding voltages on which the motor is able to run are shown under “Usable voltage”.

Nameplate voltage		Usable voltage		
230 / 400 50	277 / 480 60	240 / 415 50	220 / 380 50	265 / 460 60
190 / 330 50	220 / 380 60	208 / 360 60	230 / 400 60	
208 / 360 50	254 / 440 60	200 / 346 50	240 / 415 60	
200 / 400 50	230 / 460 60	240 / 480 60		
290 / 500 50	330 / 575 60	346 / 600 60		

It's important to understand the torque vs. RPM curves for different voltages supplied to the motor (on the side) particularly for those motors running under heavy duty. If you are supplying the brake with a lower voltage than the nominal one, the air gap has to be adjusted more frequently than in the case of nominal voltage supply in order to guarantee a constant high brake performance.

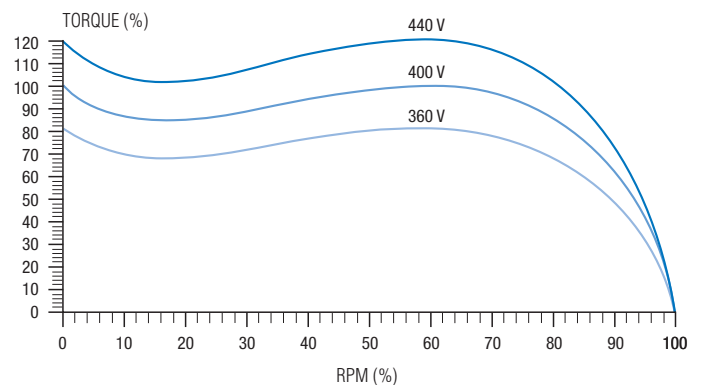

### Operating at 60Hz

MGM motors with rated voltage of 230/400V 50Hz maintain the same rated and starting torque if operating at 277/480V 60Hz, while the RPM increases by about 20% (see torque vs. RPM curves 1 and 2 here below). The AC brake coil on the BA series works equally well if operating either at 230/400V 50Hz or at 277/480V 60Hz. The DC brake coil with nameplate voltage of 110V, 230V or 400V on the BM and BA series has to be supplied at 110V, 230V or 400V single phase respectively both at 50 Hz or 60 Hz (i.e. a 230V brake can be supplied single-phase at 230V 50Hz or at 230V 60 Hz).

MGM is able to provide motors and brake coils suitable for operating on 220/380V 60Hz power supply. It is not advisable to run motors designed for 230/400V 50Hz and 277/480V 60Hz on 220/380V 60Hz voltage supply, as the power remains the same, but the starting torque is reduced by 35% (see curves 1 and 3 here below). MGM strongly recommends not to use a 277/480V 60Hz (230/400V 50Hz) AC brake coil on 220/380V 60Hz power system as it results in a significant loss of performance.

DC brakes with a rated voltage of 230V 50Hz can be used on 220V 60Hz, and those with a rated voltage of 400V 50Hz on 380V 60Hz power system. The diagram below shows different curves (torque vs. RPM) for a 230/400V 50Hz (277/480 60Hz) rated voltage motor running on different power systems.

- ① 230/400V 50Hz (277/480V 60Hz) rated voltage motor running on 230/400V 50 Hz power system.
- ② 230/400V 50Hz (277/480V 60Hz) rated voltage motor running on 277/480V 60 Hz power system.
- ③ 230/400V 50Hz (277/480V 60Hz) rated voltage motor running on 220/380V 60Hz power system.

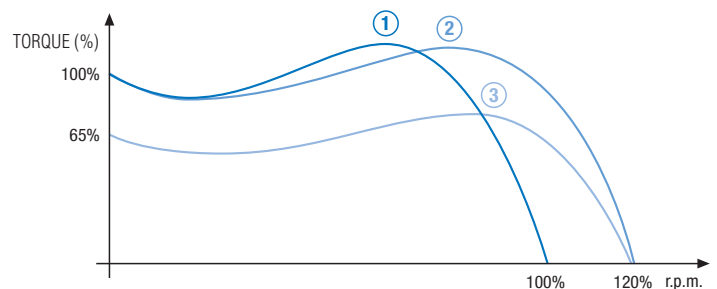

It's important to point out that, if running the motor at 60Hz instead of 50 Hz, the maximum number of starts reduces by about 15-20%, and the noise level increases by about 3dB due to the increased speed of the cooling fan.

The most common duty types are described in this paragraph and a method to calculate the permissible power rise-up is given. Please contact MGM for different types of duty.

**Continuous duty S1**

The motor operates with constant load for a period of time sufficient to achieve the thermal equilibrium.

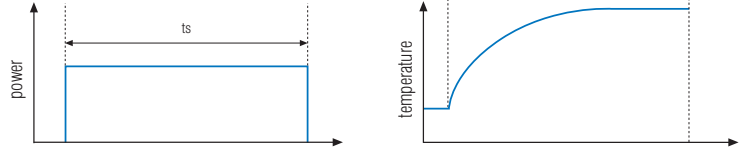

**Limited length duty S2**

The motor operates with constant load for a limited period of time not sufficient to achieve a thermal equilibrium. The remaining period of the cycle is a rest period, during which the motor cools down to the ambient temperature again.

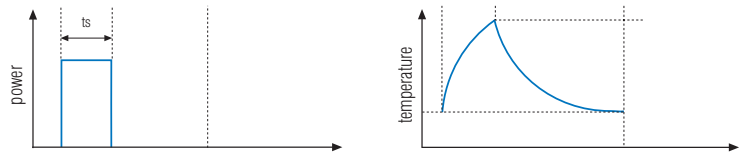

**Periodic intermittent duty S3**

The motors follows a cycle including an operation period with constant load (ts) and a rest period (tr). The synthetic indication of the duty is given by the intermittent percentage ratio related to a period of time, which usually is 60 min. (f.e. 15% - 60 min.)

$$\text{Intermittence ratio} = \frac{ts}{ts + tr} \cdot 100\%$$

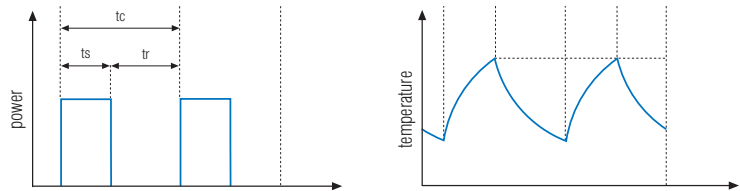

**Periodic intermittent duty with starting S4**

The motor operates on identical cycles, significant start-up time (ta) and a period with a constant load (ts). In the residual cycle time, the motor is under rest conditions (tr). Intermittent duty means that no thermal equilibrium is reached during the operating part of the cycle.

The proper indication for this cycle is S4 followed by the intermittent duty ratio, by the motor moment of inertia (JM) and by the load moment of inertia (Jext), with the latter two referred to the motor shaft. S4 Intermittent duty power temperature.

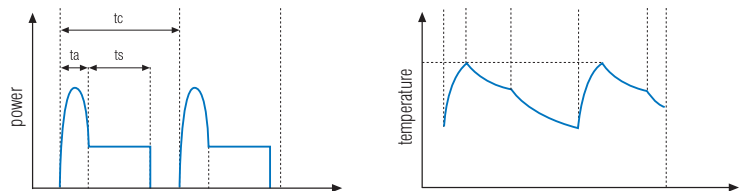

Example: S4 25 % JM = 0,15 kgm<sup>2</sup> Jext = 0,7 kgm<sup>2</sup>

$$\text{Intermittent duty ratio} = (ta + ts) / tc$$

In case of limited length duty (S2) or periodic intermittent duty (S3) an increase in power is obtainable, compared to that achieved in a continuous duty due to the reduced effects of motor warming; starting torque remains unchanged. As an indication for the single speed motors you can use the following formula:

$$\text{Available Power} = K \cdot \text{Rated power}$$

Where "K" is a coefficient obtainable from the diagrams on the right side.

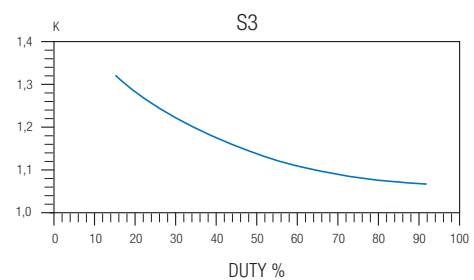
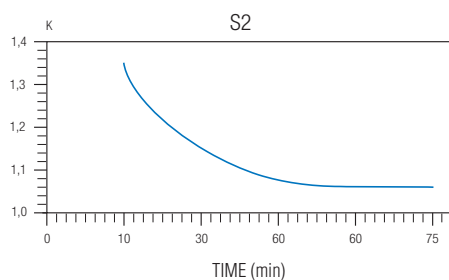

## MGM motor running on inverter

All MGM motors are designed to be suitable for inverter duty. See below to understand the motor operating under inverter control.

The motor speed depends on the power supply frequency. Basically the inverter works converting the power input from the line with a fixed amplitude and frequency (f.e. 400V 50Hz) into a voltage supply with a variable amplitude and frequency suitable to control the motor speed. Inverter can't generate an output voltage higher than the input voltage while it can increase the frequency above the input rated value; "Constant torque" regulation range indicates a range where the inverter is able to keep the nominal ratio of voltage to frequency constant; in our diagram this range is up to 50 Hz. "Constant power" (or flow) regulation range means a range where the inverter can increase frequency (and so the motor rotation speed), without voltage increase to the motor (and consequently the torque); in our diagram this range exceeds 50 Hz; Operating diagram shows the percent values of the torque available both in continuous and overloading running. When the motor is running within "constant torque" range (frequency below 50Hz), it is necessary to check that continuous running at low speed does not cause overheating.

In fact, the reduced self cooling of a motor running at low speed may cause a rise in the windings temperatures up to dangerous values for their integrity. In such situations it is recommended the use of motors with forced ventilation (-SV / -AV series). It is also advisable to use the temperature sensors to detect the temperature. When the motor is running within "constant power" range (frequency above 50 Hz), it is necessary to check if the torque required by the load does not exceed the torque indicated on the operating diagram, otherwise malfunction and eventual intervention of inverter overload protection devices could occur.

It is possible to extend the constant torque range up to 87Hz (104Hz for 60Hz environments) by connecting the motor in Delta rather than in Star (e.g., with inverter supply 400V 50Hz and motor 230/400V 50Hz).

When connected in this way the motor can deliver up to 1.7 times the rated power and as a consequence the Inverter (Variable Frequency Drive) has to be sized to provide an higher current than rated. The primary benefit of this solution is that the motor extends its constant torque range and the motor can provide the rated torque up to 1.7 times the motor RPM.

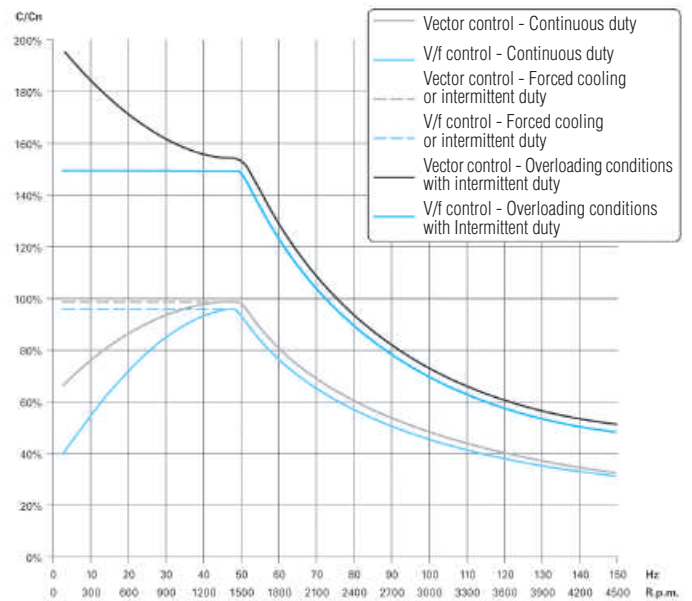

The brake should be supplied separately from the motor on brake motors controlled by inverters, to ensure the correct operation of the brake coil. In this case the double terminal board box option must be requested. On brake motors with AC brake coil, it is also advisable to use a safety overload cutout (MGM type RC04) on the power supply of the brake coil.

The starting torque of a motor running on inverter is different from the one of a motor connected directly on line. Be sure to select an inverter with technical specifications suitable for the work load of the machine it is intended to be used on.

An inverter leads to a non-sinusoidal supply waveform. Because of undesirable harmonic components added to the underlying power supply, a motor controlled by an inverter has higher losses, and an increased vibration and noise level. The efficiency reduction varies according to the type of inverter used.

Please contact MGM technical staff when using inverters with power supply higher than 400V or when using long cables between the motor and the inverter as both situations can be critical for the motor winding insulation system.

The interference generated by electronic power devices such as inverters, can influence equipment sensitive to interference, such as computers, load cells, photocells, temperature regulators, magnetic intrusion switches or capacitance grounding circuits, etc. The disturbances generated by the inverters propagate via the motor supply cables, the inverter supply cables, the grounding circuit, the control wires. Whenever it is necessary to reduce the interference caused by the inverter the following practical suggestions should be implemented. Disturbances are highest nearby the inverter and can be attenuated by increasing the distance. Sensitive devices should be kept at least 50cm from frequency converter devices. The power wiring should be kept at least 50cm away from the control wiring. Use power cables as short as possible. Power cables longer than 10m are a strong source of disturbances and can cause malfunctions. Verify the necessity of mounting an appropriate filter on the power supply line.



Balancing

MGM brake motors are dynamically balanced with half a key inserted in the shaft keyway. The table below provides the vibration limits for the different frame sizes as set forth in EN60034-14. As standard, motors are supplied with normal class balancing (class A), upon request with class B.

Balancing class	Frame size (mm)	56 ≤ H ≤ 132			132 < H ≤ 280			H > 280		
		Displacement. μm	Speed mm/s	Acc. m/s <sup>2</sup>	Displacement. μm	Speed mm/s	Acc. m/s <sup>2</sup>	Displacement. μm	Speed mm/s	Acc. m/s <sup>2</sup>
A	Free suspension	25	1,6	2,5	35	2,2	3,5	45	2,8	4,4
	Rigid mounting	21	1,3	2,0	29	1,8	2,8	37	2,3	3,6
B	Free suspension	11	0,7	1,1	18	1,1	1,7	29	1,8	2,8
	Rigid mounting	-	-	-	14	0,9	1,4	24	1,5	2,4

Reducing vibrations is important both to avoid motor damage, especially to the bearings, and to avoid damage to the machinery the motor is coupled to. It is advisable to balance the parts of the attached machinery (coupling, pulleys etc.) in order to avoid vibrations.

Noise

The noise of a running electric motor is mainly generated by the magnetic field, from the bearings and from the cooling system. The most relevant noise is generated by the cooling fan. Technical data sheets report the values of the sound pressure in dB(A) according to ISO 1680. The values are referred to a 50Hz functioning. These values should be increased by 3-5 dB about on motors operating at 60Hz due to the higher rotation speed and therefore of the fan. If motors are driven by an inverter its supply is not purely sinusoidal with higher levels of vibrations and motor noise. On request it is possible to provide motors with low noise level. During the braking action, the noise level depends on the air gap (i.e. the distance between the brake coil and the brake moving element). A periodic air gap adjustment provides lower noise levels.

Manual brake release and shaft rotation

Manual brake release might be needed to perform maintenance on the machine where the motor is installed or to manually operate the machines in case of power supply failure.

BA Series motors are equipped with a central screw to manually release the brake (for the BAH series motors there are 2 side screws). This is a 'locking' type brake release so that the brake stays disengaged until the screw is tightened on the brake assembly. Upon request the brake can be provided with a non-locking mechanism (fulcrum style).

On BM Series motors the hand release (non-locking type) is supplied on request and it's a side lever to manually release the brake. The lever is mounted on the same side as the terminal box, unless otherwise requested.

BA and BM series motors up to frame size 132mm (NEMA 245) come equipped with a hex socket on the non-drive end to manually rotate the shaft with a hex wrench once the brake is disengaged. This standard feature (MGM patent) is very useful for all those applications requiring manual positioning or a machine reset. Most of the times this feature prevents the use of a special double shaft extension needed for manual rotation. Upon request it's also possible to have motors equipped with this hex socket on frame sizes 160 and over (IEC 160 to 315).

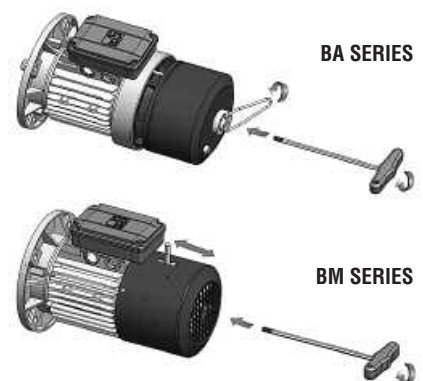

**Safety warning:** when the brake is manually released the motor shaft is no longer braked therefore is free to rotate. For this reason the manual brake release must be operated only when there are no safety concerns for any applied or suspended load. Brake must be always properly reengaged once the manual intervention is completed. Motors shall never be started with any tool inserted in the motor hex socket. Such tools must be properly removed after any manual intervention. Failure to heed these warnings could lead to serious injury and/or damage.

## temperature, altitude, humidity

The standard electrical specifications of the motors are referred to continuous duty (S1), nominal voltage, nominal frequency (50 to 60 Hz), an ambient temperature of max 40 °C and installation elevation up to 1000 m. above sea level. If ambient temperature is higher than 40 °C the permissible output power should be reduced by a percentage of the rated value (see the table below).

Ambient Temperature	40° C	45° C	50° C	55° C	60° C
Permissible Output Power as % of the Rated Power	100%	96,5%	93%	90%	86,5%

If ambient temperature is higher than 60 °C or lower than -30 °C please contact the MGM technical office. If the motor is going to work at an altitude of more than 1000 m. above sea level, the permissible output power should be reduced by percentage of the rated value (see the table below).

Altitude above sea level	1000 m.	1500 m.	2000 m.	2500 m.	3000 m.	3500 m.	4000 m.
Permissible Output Power as % of the Rated Power	100%	97%	94,5%	92%	89%	86,5%	83,5%

### Motors working in low temperature or high moisture environments

If a motor has to be used in an environment where the temperature is lower than -15 °C, in high moisture or where abrupt temperature changes can occur, it is advisable to use anti-condensation heaters. This recommendation is particularly important where there are long pauses between working cycles, which may cause abundant condensation on the motor windings. It could permeate the windings and cause short circuits. This occurs mostly on larger motors, which contain more air volume inside, allowing more humidity to condense. Two anti-condensation heaters are fitted on the windings heads in order to increase the internal motor temperature as to prevent the air condensation.

Three different types of heaters are used according to the motor size. The wiring leads of the heaters are connected to the terminal board located in the terminal box. The presence of anti-condensation heaters is shown by the writing "SCALD" followed by the required supply voltage in the field 29 of the nameplate (according to nameplate paragraph). Space heaters must be supplied to prevent moisture condensation in the motor during times the motor is not running. The heaters must not be supplied during the normal motor operation.

Additional protection against moisture may be provided by the realization of drain holes on the motor to allow water drainage. Drain holes option is provided on request only and it is necessary to specify in the order the mounting to properly position the holes on the motor.

As standard MGM motors have the stator winding and brake coil treated to work in tropical environments. However a specific tropicalization treatment can be requested, for all motors that have to be installed in high humidity environments.

For the BM series a rain roof is available on request, for outdoor use or in presence of water jets with vertical mounting and shaft down. The rain roof is positioned above the fan cover protecting the motor from water and permitting the regular flow of the cooling air. There is no need of a rain roof on BA motors thanks to its particular construction and the use of a special brake cover for outdoor vertical mounting. When brake motors are used in elevated moisture environments or where there are long periods between working cycles, brake disc sticking can occur. To avoid disc sticking it is possible to provide zinc plated or stainless steel brake friction surfaces according to the motor type.

The motor should be provided with protection devices to protect against non ordinary working conditions. The use of protection device on the line is particularly advisable (i.e. varistors) for those motors running at low speed (8, 12, 16 poles) to prevent early wear of windings and of contacts caused by voltage peaks during the switching on. It is advisable to use proper torque limiters in those application where the motor shaft could be impeded. The chart below reports the most effective protection devices for the most frequent occurring problems.

Operation conditions	Protection type		
	Fuses	Protective circuit breakers	Thermal protective device on the windings
Excess currents 200% In	no protection	excellent protection	excellent protection
Heavy starts, reversing operation	no protection	partial protection	excellent protection
Stalling	partial protection	partial protection	partial protection
Starting on two phases	no protection	partial protection	excellent protection
Voltage deviations	no protection	excellent protection	excellent protection
Frequency deviations	no protection	excellent protection	excellent protection
Insufficient motor cooling	no protection	no protection	excellent protection

On request MGM is able to supply motors equipped with:

**Bimetallic Thermal Protectors (PTO):** three bimetallic sensors in series with normally closed contacts, fitted on the windings heads. They control a switch (not provided with the motor) that interrupts the power supply when getting close to a dangerous temperature. The nominal voltage and current are 250 V and 2,5 A AC. The contact closes again with a temperature reduction of at least 35 °C. The bimetallic thermal protectors leads are connected to a terminal board located in the main terminal box.

The temperature of intervention of the sensors is 140° C. Different temperatures of intervention are available on request.

**Thermistors (PTC):** three thermistors in series (conforming to DIN standards 44081 and 44802), fitted on the windings heads. The resistance of the thermistors changes with temperature and when getting close to the nominal intervention temperature the sharp increase of resistance guarantees a precise intervention of the safety devices. The thermistor only senses the temperature so a cut-out device (not provided with the motor) must be added to interrupt the power supply to the motor. The maximum PTC operating voltage is 30 V DC. The PTC leads are connected to a terminal board located in the main terminal box.

The temperature of intervention of the the sensors is 130° C. Different temperatures of intervention are available on request.

**PT 100 sensors:** sensors (conforming to DIN EN 70751) fitted on windings heads. The resistance of PT 100 sensors linearly changes with temperature.

**Over-voltage protection**

**Brake coil:** DC brake coil is supplied as standard with a rectifier fitted with an over-voltage protection device. The AC brake coil doesn't generally need this type of protection devices. In case of a very high start/stop frequency or in case of critical line voltage situation it is recommended the use of RC04 filter in order to limit the electrical stress on the brake coil.

**Low speed motors:** when starting motors with a high number of poles (i.e. 8, 12, 16), voltage peaks can be generated damaging the motor insulation materials and contacts. In these cases it is advisable to install safety over-voltage protection devices. On request MGM provides over-voltage protection devices such as RC04 for motors up to 4 kW and RC10 for motors up to 10 kW. Please note that these devices should not be installed if the motor is controlled by an inverter.

Efficiency indicates how well an electric motor transforms electrical energy into mechanical energy. The higher the efficiency of a motor in specific operating conditions, the lower is its energy consumption. International standard IEC 60034-30-1 defines efficiency classes through the code "IE" followed by a number.

- IE1 (standard efficiency)**
- IE2 (high efficiency)**
- IE3 (premium efficiency)**
- IE4 (super premium efficiency)**

The Standard IEC 60034-30-1 defines motor efficiency classes, but it doesn't legally determine minimum efficiency requirements. As a matter of fact the standard does not specify if motors shall comply with a minimum efficiency class. Minimum efficiency standard are instead specified by individual countries laws.

Commission Regulation 640/2009 (amended by regulation 4/2014), in force in Europe till the 30<sup>th</sup> of June 2021, determines motors minimum efficiency levels and it applies to squirrel cage induction motors with single speed (2, 4, and 6 poles), three-phase 50 Hz or 60 Hz, power from 0.75 kW up to 375 kW, nominal voltage up to 1000 V and working on continuous duty (S1).

Some motor categories are excluded from this regulation.

Brake motors are not included in the application field of this European Regulation.

The new European regulation (regulation EU 2019/1781), on the other hand, it establishes new requirements for brake motors rated for operation on a 50 Hz, 60 Hz or 50/60 Hz sinusoidal voltage, rated voltage above 50 V and up to and including 1000 V and continuous duty (S1, S3 ≥ 80%, S6 ≥ 80%) operation, starting from the 1<sup>st</sup> of July 2021.

**Starting from the 1<sup>st</sup> of July 2021:**

- three phase brake motors with rated power  $0,75 \text{ kW} \leq P_N \leq 1000 \text{ kW}$  with 2, 4, 6, 8 pole, must be IE3.
- three phase brake motors with rated power  $0,12 \text{ kW} \leq P_N < 0,75 \text{ kW}$  with 2, 4, 6, 8 pole, must be IE2.

**Starting from the 1<sup>st</sup> of July 2023:**

- single phase brake motors with rated power  $P_N \geq 0,12 \text{ kW}$  with 2, 4, 6, 8 pole, must be IE2.

The new regulation doesn't apply to some types of motors among which 2 speed motors and TENV motors.

The following table shows the technical data of BAX and BMX series motors (three phase brake motors) with efficiency class IE2 (rated power  $P_N < 0,75 \text{ kW}$ ) and IE3 (rated power  $P_N \geq 0,75 \text{ kW}$ ) that comply with the new efficiency regulation. The provided data refers to 50 Hz motor operation.

Motor Efficiency regulations are different for each country in the world with regards to minimum efficiency levels, exclusions and deadlines. As regulations are subject to changes please contact MGM technical department for the most updated information about efficiency regulations.

For a quick calculation of the annual economic savings using a motor with an efficiency ( $eff_a$ ) instead of a motor with an efficiency ( $eff_b$ ) with the same rated power you can consider the following formula:

$$\text{Annual economic savings} = H_{\text{year}} \times \text{kW} \times \%FL \times \text{Costkwh} \times (1/eff_a - 1/eff_b)$$

$H_{\text{year}}$  = annual motor running (hours)

$\text{kW}$  = motor rated power (kW)

$\% FL$  = fraction of full load power at which motors effectively run

$\text{Costkwh}$  = electricity cost

$eff_a$  = motor 'a' efficiency (%) at the effective load condition / 100

$eff_b$  = motor 'b' efficiency (%) at the effective load condition / 100

BAX and BMX motor series have the same brake components as the BA and BM series, therefore the braking performance are the same.



Upon request BA, BAX, BM, BMX brake motors and derivative series can be provided with cCSAus approval (complying with CSA C22.2 No.100 and UL 1004-1 standards). Only cCSAus approved motors show the relevant marking on the nameplate.

It's possible to download the CSA certificate from our website ([www.mgmrestop.com](http://www.mgmrestop.com)) under the section DOCUMENTATION → QUALITY.

Motor sold in USA and in Canada must also comply with the energy efficiency regulation. Single speed, asynchronous motors with and without brake, with power greater than 0.75 kW (from 1HP up to 500HP) and rated for continuous operations are covered by the USA and Canada energy efficiency regulation and need to meet Premium efficiency levels (equivalent to IE3). Some motors including double speed and intermittent duty motors (S2÷S10) are excluded by the Canadian and American regulations.

MGM brake motors series BAX and BMX with 2, 4, 6 poles and powers from 0.75kW up to 45kW (1HP to 60HP) comply with this regulation. Motors complying with the North American efficiency regulation show the "Certification Compliance Number" (CC number) issued by the US Department of Energy (DOE) and the cCSAus "Energy Verified" mark on the nameplate according to the Canadian regulations. The certification covers various options including thermal protectors and thermistors, space heaters, encoders, etc. Please contact MGM for more information on the available certified options.

For those motors intended for intermittent duty (S2÷S10) and therefore not covered by the efficiency regulation, the brake motors belonging to the BA and BM series can be supplied. In this case on the name plate will be stated the intermittent duty and just the cCSAus logo (but not the CC number and the "Energy Verified" indication).

The MGM laboratory is certified by CSA to perform safety tests required for the cCSAus certification as well as the efficiency tests to determine the motor efficiency. It's possible to download these certificates from our website ([www.mgmrestop.com](http://www.mgmrestop.com)) under the section DOCUMENTATION → QUALITY.

MGM motors can be provided with two different winding configurations: Δ/Y (Delta/Star) 6 wires European standard or Y/YY (Wye/double Wye) 9 wires American standard, 3ph 230/460V 60Hz.

Motors with NEMA flanges and shafts are available on request (see page 9).

In the purchase order it's always necessary to specify the following information to MGM:

- cCSAus certification requirement;
- The required duty (Continuous or Intermittent) in case of single speed motors;
- The motor and brake coil voltage.

SMX series are non-brake 3-phase asynchronous motors with 2, 4, 6 poles and powers from 0.75kW (1HP) up to 45kW (60HP) and comply with the cCSAus standards and energy efficiency regulation. SMX motors series bear the "Certification Compliance Number" along with cCSAus 'Energy Verified' mark on the nameplate.



100% of manufactured motors undergo a final routine test and safety checks (dielectric rigidity and the insulation resistance test) as well as a no load test. Upon request, at the purchase order time, motors can be provided with the relevant **MGM routine test certificate**. The certificate reports the motor serial number and the routine test results.

The following documents can also be provided on request:

**Type Test Certificate:** this certificate represents the tests carried out on prototypes or on samples from production. It reports data concerning the type of motor therefore it doesn't report specific motor information. It provides the data from the motor at "no load" and at "load" as well as the electrical safety tests. The motor serial number isn't provided in such a certificate.

**Test Certificate:** this certificate represents the tests carried out on a specific motor. It provides the data from the motor at "no load" and at "load" as well as the electrical safety tests. This time the motor serial number is provided in such a certificate.

Additional tests such as noise, vibration, brake torque, dimensions and protection degree (enclosure) rating can be provided by MGM upon request at the time of the purchase order. Please contact MGM to be quoted concerning the above tests and certificates.

Painting

The table below shows the available painting plans. MGM primarily chooses water-based paint rather than solvent-based ones in order to minimize the environmental pollution impact. Unless otherwise specified or required by the application, aluminium parts are provided unpainted.

Painting plans	Notes	Intended use
Standard	All cast iron parts are painted with water-based paint. Brake cover is powder coated both internally and externally. Aluminium parts are left unpainted. Body, flanges and end-bells of motors from frame size IEC 160 and over are made of cast iron, and painted externally with water-base epoxy paint. The MGM standard colour is RAL 5010.	Industrial environments, no harsh chemicals and protected from the weather.
Outdoor	One epoxy primer coating and one coating of enamel.	Industrial environments with high humidity levels, no harsh chemicals, outdoor installations exposed to the weather (not in proximity to coastal areas) with moderate pollution.
Marine	Two coatings of epoxy primer and one coating of enamel.	Industrial environments with high humidity, moderate environmental contamination, outdoor installations exposed to weather, coastal areas with moderate salinity (not offshore).
Offshore	One coating of epoxy primer, two coating of epoxy paint, one coating of enamel.	Installations on vessels/ships or offshore units.

Upon requests, painting plans can be applied according to corrosion classes (C3, C5-M, etc.) as set forth in the ISO 12944 standard (Paints & Varnishes - Corrosion protection of steel structures by protective paint systems).

On request an additional corrosion protection on the internal parts like rotor, casing, stator, etc. can be provided (stated as 'VER-INT') and, still on request, a winding tropicalization treatment can be applied ('TROP').

Painting plan and colour RAL number shall be specified at the time of the purchase order. Make sure that the protection (enclosure) rating is suitable for the intended installation and evaluate if the application requires drain holes and/or anti-condensation heaters.

B5

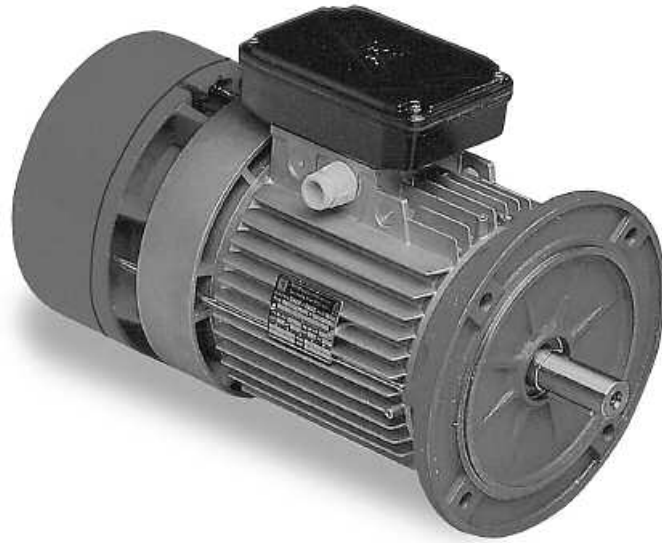

B14



B3

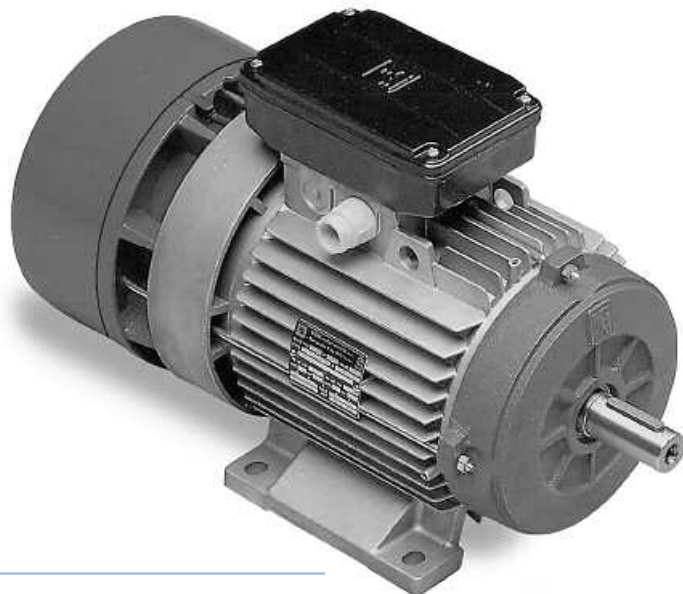



**BA Series**

BA series consists of three phase, asynchronous brake motors. The brake is activated in case of power supply failure. The brake torque remains the same in both directions of rotation and the motor brakes without shaft axial sliding. As standard the brake is AC 3-phase voltage supply with brake leads connected with motor leads in a single terminal board box while. On request it is possible to supply the brake separately with a second terminal board or to have a DC brake supply with a built-in rectifier fitted inside the terminal box. The rectifier is provided with over-voltage protection devices. BA series motors tolerate high overloading rates and are capable of withstanding overheating in such a way that guarantees the best reliability even under tough operating conditions. All MGM series motors have been designed to be controlled by inverters. The motor winding insulation is class F, while class H is available on request. Motor construction type is totally enclosed externally cooled (TEFC) and IP54 enclosure (IP55, IP56, IP65 and IP66 are available on request). Motors up to 132 frame size are fitted as standard with a hexagonal hole on the shaft at the non drive end to allow manual rotation, even if power is off. All BA series motors are provided as standard with hand brake release screw.

BA series brake disc has a large lining surface that allows high brake torque, low disc wear and consequently low maintenance cost. The brake torque can be easily adjusted to the desired value just by screwing some nuts. Thanks to its special construction the brake friction surface is self-ventilated on the motor side, permitting a high brake workload and keeping brake time constant. The brake lining material is asbestos free.

BA series motor frame is made of die cast, light metal on motors up to 132 size and the terminal board box, provided with cable glands and plugs, is positioned 180° above the motor support feet. The frame is made of cast iron starting from 160 frame size and the terminal box is located on the right side (drive-end view). Shields and flanges are made of aluminium on motors up to 90 frame size, and of cast iron on motors of 100 frame size and above. As standard feet are frame integrated (they are not simply attached to the frame) on IM B3 mounting (foot mounted) making the motor very sturdy. This feature is very important for those applications where the motor is much stressed during the starts and stops. The brake friction surfaces are made of cast iron as a standard. The brake moving element and the brake coil have a laminated nucleus to reduce electrical losses and to secure a very quick brake intervention.

BA series main features are its sturdy construction, quick braking action, constant braking time, high number of permissible start/stop cycles also under severe applications, easily adjustable brake torque, low maintenance costs.

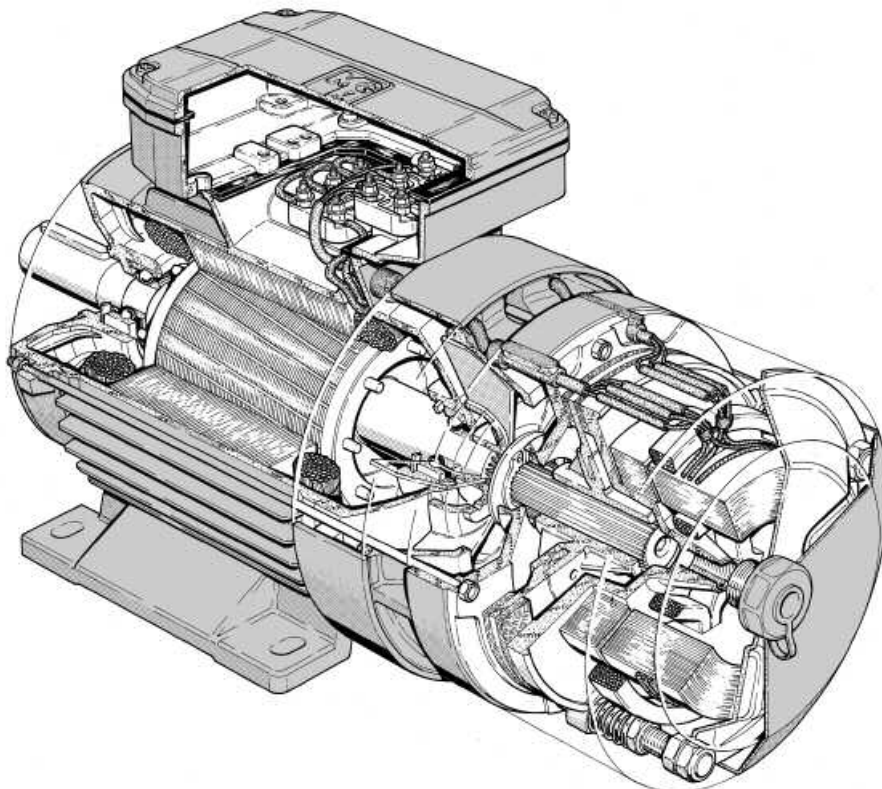

# BA series brake group

## Air gap adjustment

The air gap (60), that is the distance between the two magnetic cores, the brake coil (25) and brake moving element (24), must stay within the value expressed in the chart below. It is not advisable to exceed the expressed value, in order to avoid vibrations of the brake moving element, very loud noise, the brake coil burning or even the whole brake assembly failure. It is advisable to check periodically the air gap because it increases as a consequence of the brake disc wear. In order to set the air gap to the indicated value, loosen the nuts (21-22) so to move the brake coil (25) towards the brake moving element (24). Once this operation has been settled be sure to tighten the locknuts. The above mentioned procedure isn't valid for BA 250-280 serie-motors, for which we please you to contact us.

Frame Size	71-80	90-100	112-132	160+200	225+315
Min Air Gap [mm]	0.25	0.3	0.35	0.45	0.5
Max Air Gap [mm]	0.6	0.7	0.8	1.0	1.1

## Brake torque adjustment

The brake torque is proportional to the springs (18) compression, which can be adjusted tightening or loosening the locknuts (20). The compression of the three springs must be as even as possible. Once the brake is properly supplied, if the brake coil isn't able to attract the brake moving element with a quick stroke and to keep it attracted without any vibrations, check the air gap adjustment. If this inconvenience still persists, loosen the locknut (20) by two threads and try again until the proper functioning is obtained. It is important to consider that some motors can be equipped with 3 springs and some others with 6 (see page 27). Once this operation is completed, check the brake torque to make sure it is set to the desired value. Never set the brake torque to a higher value than the one indicated on the motor nameplate.

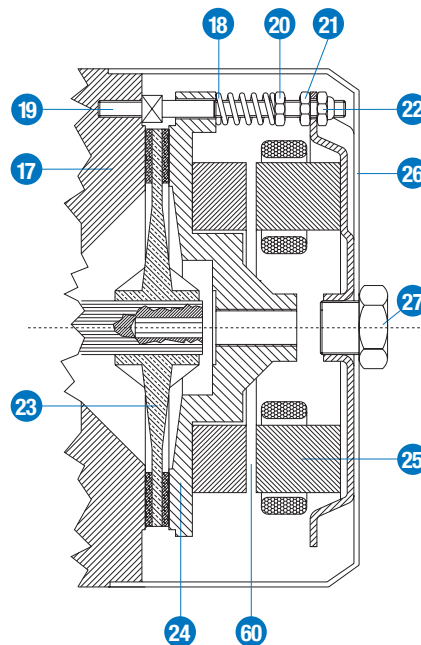

## Permissible start frequency at load

The technical data tables provide the ideal no-load start frequency ( $Z_0$ ). The permissible start frequency when an external load is applied ( $Z_{load}$ ) can be found with the following formula:

$$Z_{load} = Z_0 \cdot K \cdot R$$

where "Z<sub>0</sub>" is the table-value for the selected motor and "K" and "R" are factors determined by the curves on the side; the factor "K" is related to the ratio of the moment of inertia of the applied load ( $J_{app}$ ) and to that of the motor ( $J_{mot}$ ) while the factor "R" is related to the ratio of the resisting torque ( $T_r$ ) to the starting torque ( $T_s$ ). This calculation gives an approximative indication only and it has to be operatively tested for confirmation. If the required starting frequency is close to  $Z_{load}$ , it is advisable to use a motor equipped with thermal protectors. It is necessary to check the maximum energy dissipation limit of the brake group and the maximum motor RPM in those applications where high moment of inertia is involved. On request, a special brake disc material is available, which is capable of withstanding a very high dissipation energy. Please contact MGM technical staff for additional information.

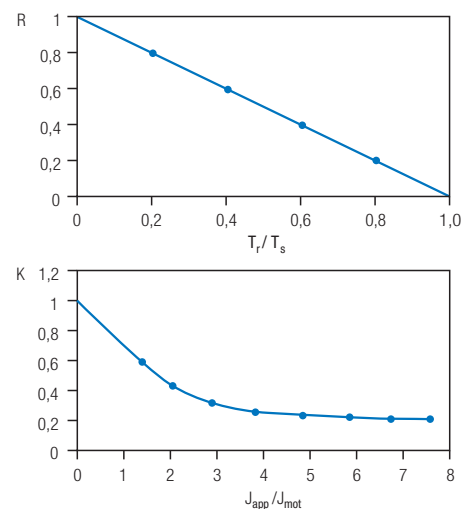

## Brake coil wiring diagram

As standard BA series motors are equipped with AC brakes with single terminal board for the brake and the motor, while on request it is possible to supply the brake separately. The AC brake coil can be star or delta connected. On request DC brakes are available for BA series with the rectifier located inside the terminal box. The rectifier is provided with over-voltage protection devices and with a RFI filter. MGM brake motors equipped with DC brakes can be connected as in diagram A or B according to the required braking time. MGM motors provided with DC brake coil are connected as diagram A. The DC brake coil has to be connected according to diagram B to have a reduced brake reaction time.

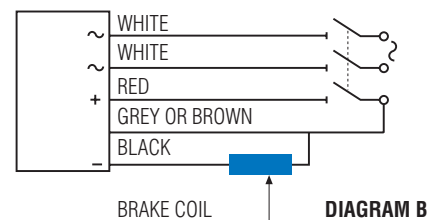
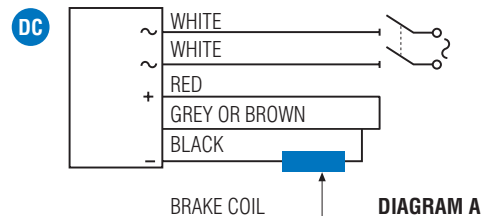
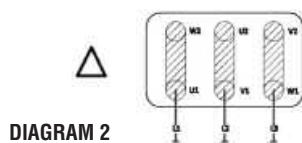
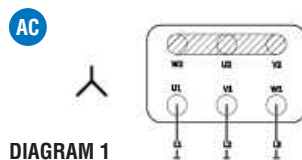

# brake torque and brake springs compression



BA series

BA series motors are provided as standard with a brake torque set to 60-70% of the maximum admissible brake torque indicated on the nameplate. On request the motor can come already set to a specific brake torque value different from the standard one. The brake torque is shown in the diagrams here below as a function of the brake assembly spring compression; for BA 225-315 motors diagrams please contact MGM.

The shown values refer to BA series motors mounted in horizontal position with an AC brake coil. DC brakes have the same trend as AC brakes even if they have lower brake torque, as shown in the table below. For BAK 90-132 motors series the brake torque changes in a different way than shown in the diagrams. Please contact MGM for further information. The values shown in the diagrams are only indicative as application conditions, brake lining wear and temperature, can affect the real brake torque. Whenever it is necessary to adjust the braking torque to a specific value it is advisable to directly measure the obtained brake torque after each brake torque adjustment. Consider that the motor mounting position influences remarkably the effective braking torque when low brake torque values are involved. Please contact MGM for further information.

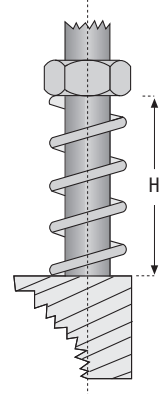

BA series motor type	71	80	90	100	112	132	160	180	200	225	250	280	315
Max AC Brake Torque (Nm)	14	18	38	50	80	150	190	300	300	600	700	1000	1300
Max DC Brake Torque (Nm)	9	15	30	42	60	120	155	180	180	600	-	-	-

**BA 71**

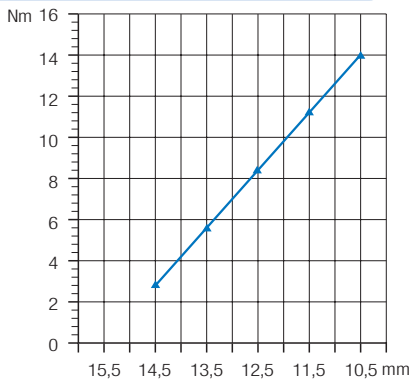

**BA 80**

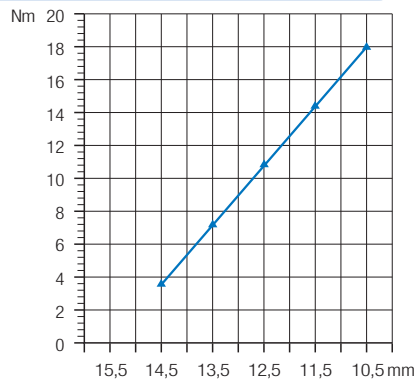

**BA 90**

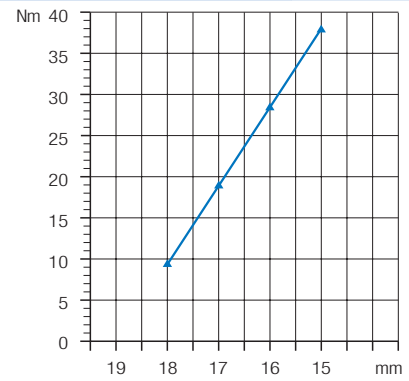

**BA 100**

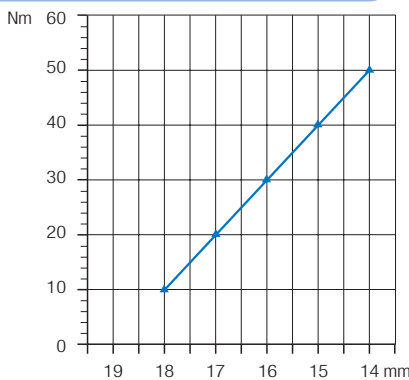

**BA 112**

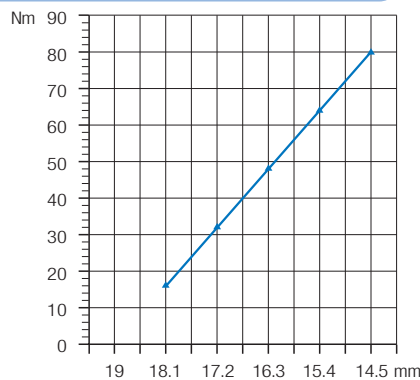

**BA 132**

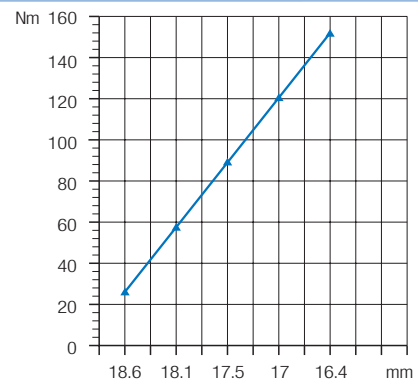

For BA 225-250-280-315 motors diagram please contact MGM.

**BA 160**

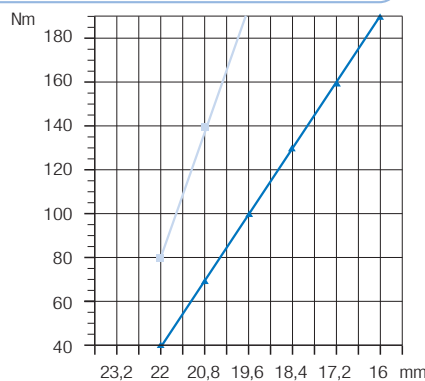

**BA 180-200**

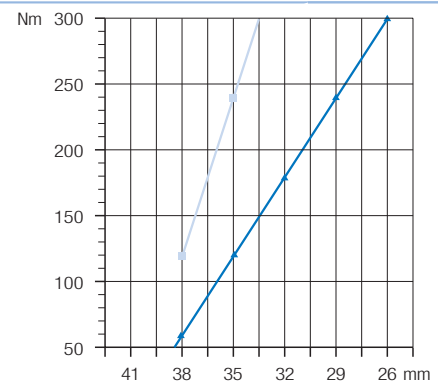

Light blue line: 6 springs brake group  
Blue line: 3 springs brake group  
Consider that DC brake groups always have 3 springs and 155 Nm max. brake torque.

Light blue line: 6 springs brake group  
Blue line: 3 springs brake group  
Consider that DC brake groups always have 3 springs and 180 Nm max. brake torque.

# technical data single speed motors - single winding

## IE1 - 50 Hz

Motor type	Power (kW)	RPM	In (A) 400 V	cos φ	Eff.	Tn (Nm)	Ts / Tn	Is / In	AC brake In (mA)	DC brake In (mA)	Z <sub>0</sub> (starts /hour)	Moment of inertia Jx 10 <sup>-4</sup> Kgm <sup>2</sup>	Max AC brake torque (Nm)	A-Sound pressure dB (A)	Weight (Kg)
2 pole - 3000 RPM															
BA 71 A2	0.37	2810	0.90	0.78	69.4	1.26	2.6	4.5	90	110	6000	4.88	14	59	9.5
BA 71 B2	0.55	2810	1.40	0.78	72.0	1.87	2.6	4.5	90	110	6000	5.48	14	59	10.5
BA 71 C2*	0.75	2810	1.8	0.80	73.2	2.55	2.5	4.5	90	110	5000	6.15	14	59	11.0
BA 80 A2	0.75	2800	1.7	0.86	74.0	2.56	3.1	5.3	140	150	6000	11.64	18	65	14.5
BA 80 B2	1.1	2800	2.4	0.86	76.5	3.75	3.1	5.3	140	150	6000	12.96	18	65	15.5
BA 90 SA2	1.5	2850	3.2	0.86	77.2	5.03	3.0	6.9	300	150	4500	18.95	38	72	20.0
BA 90 LA2	2.2	2840	4.5	0.86	79.7	7.40	3.0	6.9	300	150	4500	21.84	38	72	22.5
BA 100 LA2	3.0	2900	6.3	0.81	81.5	9.88	2.2	7.6	300	150	2800	39.82	50	74	30.0
BA 112 MB2	4.0	2880	8.1	0.84	83.1	13.26	2.5	7.4	280	470	1700	68.96	80	75	44
BA 112 MC2*	5.5	2880	11.4	0.85	84.7	18.24	2.5	7.4	280	470	1400	85.00	80	75	48
BA 132 SA2	5.5	2890	10.8	0.86	84.7	18.17	2.8	7.4	580	680	480	192.0	150	75	71
BA 132 SB2	7.5	2890	14.6	0.85	86.9	24.78	2.8	7.4	580	680	480	231.0	150	75	77
BA 132 MA2*	9.2	2890	17.9	0.85	86.9	30.40	2.8	7.4	580	680	420	270.0	150	75	83
BA 132 MB2*	11.0	2890	21.4	0.85	85.7	36.35	2.8	7.4	580	680	400	308.0	150	75	90
BA 160 MA2	11.0	2920	19.5	0.94	88.0	35.98	3.0	8.6	1390	860	350	537.0	190	77	160
BA 160 MB2	15.0	2930	26.3	0.93	89.2	48.89	3.1	8.8	1390	860	350	537.0	190	77	160
BA 160 LA2	18.5	2930	32.4	0.93	89.4	60.30	3.1	8.8	1390	860	350	616.0	190	77	171
BA 180 LA2	22.0	2950	36.7	0.95	89.9	71.22	2.7	9.0	950	1100	120	1150.0	300	78	243
BA 200 LA2	30.0	2940	52.0	0.94	89.4	97.45	2.8	9.0	950	1100	90	1160.0	300	79	274
BA 200 LB2	37.0	2940	64.1	0.93	89.9	120.19	2.8	9.0	950	1100	90	1290.0	300	79	289
4 pole - 1500 RPM															
BA 71 A4	0.25	1400	0.8	0.65	63.0	1.71	2.5	3.7	90	110	20000	7.20	14	45	9.5
BA 71 B4	0.37	1400	1.10	0.68	67.0	2.52	2.7	3.9	90	110	19000	8.10	14	45	10.5
BA 71 C4*	0.55	1360	1.65	0.70	70.0	3.86	2.4	3.7	90	110	18000	9.43	14	45	11.5
BA 71 D4*	0.65	1350	2.00	0.69	71.7	4.60	2.1	3.7	90	110	16000	9.92	14	45	12.0
BA 80 A4	0.55	1400	1.70	0.69	70.0	3.75	2.1	4.0	140	150	10000	14.97	18	47	14.0
BA 80 B4	0.75	1400	2.20	0.67	73.5	5.12	2.5	4.3	140	150	10000	17.19	18	47	15.0
BA 80 C4*	0.9	1390	2.60	0.67	73.6	6.18	2.8	4.5	140	150	10000	18.30	18	47	16.0
BA 90 SA4	1.1	1400	2.7	0.77	77.4	7.50	2.3	4.6	300	150	15000	26.15	38	55	20.0
BA 90 LA4	1.5	1400	3.6	0.75	78.3	10.23	2.7	4.8	300	150	12000	30.53	38	55	22.5
BA 90 LB4*	1.85	1400	4.3	0.77	78.7	12.62	2.7	5.8	300	150	9000	34.57	38	55	24.0
BA 90 LC4*	2.2	1390	5.4	0.75	77.3	15.12	2.7	5.0	300	150	7000	34.57	38	55	24.0
BA 100 LA4	2.2	1410	5.0	0.78	80.8	14.90	2.5	5.4	300	150	8000	51.14	50	57	32
BA 100 LB4	3.0	1410	6.5	0.80	83.1	20.32	2.8	6.4	300	150	7000	60.07	50	57	36
BA 112 MB4	4.0	1415	8.1	0.84	83.7	27.00	2.6	6.4	280	470	4000	125.7	80	61	45
BA 112 MC4*	5.5	1420	11.5	0.83	84.7	36.99	2.8	6.9	280	470	3500	145.0	80	61	50
BA 132 SB4	5.5	1430	11.3	0.82	85.2	36.73	2.4	6.0	580	680	1200	277.0	150	62	78
BA 132 MA4	7.5	1435	14.8	0.84	86.4	49.91	2.4	6.0	580	680	950	352.0	150	62	87
BA 132 MB4*	9.2	1445	18.3	0.85	87.3	60.80	2.5	6.3	580	680	900	432.0	150	62	100
BA 132 MC4*	11.0	1440	21.7	0.86	87.6	72.95	2.5	6.0	580	680	800	432.0	150	62	100
BA 160 MA4	9.2	1460	18.6	0.84	87.2	60.18	3.0	7.0	1390	660	850	604.0	190	63	148
BA 160 MB4	11.0	1460	21.2	0.85	88.0	71.95	2.9	7.0	1390	860	850	683.0	190	63	154
BA 160 LA4	15.0	1460	28.5	0.87	89.7	98.12	2.7	7.0	1390	860	850	858.0	190	63	171
BA 180 LA4	18.5	1460	33.7	0.89	90.6	121.01	2.9	8.0	950	1100	540	1740	300	64	243
BA 180 LB4	22.0	1460	41.8	0.85	90.0	143.90	2.5	7.6	950	1100	540	1740	300	64	243
BA 200 LB4	30.0	1455	56.5	0.87	90.7	196.91	2.5	7.4	950	1100	300	1980	300	66	274
BAH 225 S4**	37.0	1475	68.1	0.85	92.7	239.56	2.5	7.9	2000	1000	300	4470	600	68	392
BAH 225 M4**	45.0	1475	82.6	0.85	93.1	291.36	2.5	7.9	2000	1000	300	5140	600	68	440
BAH 250 M4**	55.0	1470	100	0.85	93.5	357.00	3.5	8.8	2000	-	120	7690	700	70	665
BAH 280 S4**	75.0	1480	132	0.86	94.0	487.00	2.8	8.0	2000	-	100	8390	1000	70	770
BAH 280 M4**	90.0	1470	157	0.88	94.2	584.00	2.7	7.5	2000	-	100	8890	1000	70	810

### IE1 - 50 Hz

Motor type	Power (kW)	RPM	In (A) 400 V	cos φ	Eff.	Tn (Nm)	Ts / Tn	Is / In	AC brake In (mA)	DC brake In (mA)	Z <sub>0</sub> (starts /hour)	Moment of inertia Jx 10 <sup>-4</sup> Kg·m <sup>2</sup>	Max AC brake torque (Nm)	A-Sound pressure dB (A)	Weight (Kg)
6 pole - 1000 RPM															
BA 71 A6	0.18	875	0.60	0.71	56.0	1.96	2.0	2.6	90	110	28000	10.08	14	45	10.5
BA 71 B6	0.25	900	0.80	0.71	59.0	2.65	2.0	2.8	90	110	28000	11.54	14	45	11.0
BA 80 A6	0.37	910	1.25	0.67	64.0	3.88	2.6	3.4	140	150	18000	23.40	18	47	14.5
BA 80 B6	0.55	900	1.8	0.68	65.8	5.84	2.2	2.8	140	150	18000	27.21	18	47	15.5
BA 90 SA6	0.75	910	2.3	0.68	70.1	7.87	2.1	3.5	300	150	18000	35.93	38	54	19.5
BA 90 LA6	1.1	910	3.2	0.68	72.9	11.54	2.2	3.6	300	150	15000	46.08	38	54	22.0
BA 90 LB6*	1.3	910	3.9	0.68	74.2	13.64	2.5	4.0	300	150	12000	53.00	38	54	24.0
BA 100 LA6	1.5	930	3.9	0.71	78.6	15.40	2.3	4.3	300	150	11000	87.40	50	56	33
BA 100 LB6*	1.85	920	5.0	0.68	76.6	19.20	2.6	4.5	300	150	8500	99.19	50	56	35
BA 112 MB6	2.2	945	5.2	0.79	78.2	22.23	2.0	5.3	280	470	6500	168.3	80	58	45
BA 132 SB6	3.0	960	7.2	0.72	83.0	29.84	2.5	6.5	580	680	1800	346.0	150	58	78
BA 132 MA6	4.0	960	9.5	0.72	83.9	39.79	2.3	6.5	580	680	1500	401.0	150	58	83
BA 132 MB6	5.5	960	12.3	0.75	84.3	54.71	2.3	6.5	580	680	1200	508.0	150	58	94
BA 160 MB6	7.5	965	15.9	0.79	85.3	74.22	2.2	7.1	1390	860	1200	943.0	190	59	156
BA 160 LA6*	9.2	970	18.3	0.81	87.0	90.58	2.2	7.1	1390	860	1100	1240.0	190	59	174
BA 160 LB6	11.0	970	22.7	0.80	88.0	108.30	2.5	7.5	1390	860	950	1240.0	190	59	174
BA 180 LB6	15.0	970	29.4	0.84	89.0	147.68	2.3	7.8	950	1100	600	2070.0	300	60	243
BA 200 LA6	18.5	970	38.1	0.82	88.6	182.14	2.2	8.0	950	1100	350	2360.0	300	61	289
BA 200 LB6	22.0	965	43.5	0.85	89.2	217.72	2.2	8.0	950	1100	350	2360.0	300	61	289
BAH 225 M6**	30.0	980	60.7	0.78	91.7	292.35	2.6	6.5	2000	1000	350	7470.0	600	63	440
BAH 250 M6**	37.0	985	73.0	0.78	92.2	358.00	2.7	6.6	2000	-	200	10090.0	700	65	675
BAH 280 S6**	45.0	985	87.0	0.80	92.7	436.00	2.6	6.3	2000	-	160	10690.0	1000	65	750
BAH 280 M6**	55.0	985	105.0	0.80	93.1	533.00	2.5	6.0	2000	-	160	11640	1000	65	790
8 pole - 750 RPM															
BA 71 A8	0.08	660	0.60	0.53	42.9	1.16	2.0	2.0	90	110	30000	7.20	14	43	10.0
BA 71 B8	0.11	660	0.80	0.55	43.7	1.59	2.0	2.0	90	110	30000	8.10	14	43	10.5
BA 80 A8	0.18	675	0.95	0.59	50.3	2.55	2.0	2.2	140	150	30000	23.40	18	45	14.5
BA 80 B8	0.25	675	1.25	0.62	52.1	3.54	2.0	2.2	140	150	30000	27.21	18	45	15.5
BA 90 SA8	0.37	680	1.50	0.60	60.6	5.20	2.1	2.9	300	150	20000	35.93	38	46	20.0
BA 90 LA8	0.55	690	2.20	0.56	61.4	7.61	2.1	2.8	300	150	17000	46.08	38	46	22.5
BA 90 LB8*	0.65	690	2.70	0.56	64.9	9.00	2.1	2.8	300	150	14000	53.00	38	46	24.0
BA 100 LA8	0.75	700	2.75	0.58	68.1	10.23	2.1	3.0	300	150	14000	87.40	50	49	33.0
BA 100 LB8	1.1	700	4.1	0.59	70.2	15.01	2.5	4.0	300	150	9400	99.19	50	49	35.0
BA 112 MB8	1.5	705	4.9	0.60	73.6	20.32	2.0	4.5	280	470	7200	168.3	80	52	45
BA 132 SB8	2.2	700	5.2	0.75	80.8	30.01	2.1	4.7	580	680	2100	325.0	150	55	73
BA 132 MB8	3.0	700	7.1	0.75	80.8	40.93	2.1	4.7	580	680	2100	413.0	150	55	80
BA 160 MA8	4.0	725	9.6	0.72	83.1	52.69	2.3	6.5	1390	860	1800	1030.0	190	58	156
BA 160 MB8	5.5	725	13.6	0.70	83.5	72.45	2.3	6.1	1390	860	1800	1030.0	190	58	156
BA 160 LA8	7.5	725	18.6	0.70	83.8	98.79	2.3	6.1	1390	860	1800	1360.0	190	58	174
BA 180 LB8	11.0	730	25.9	0.72	85.8	143.90	2.0	5.9	950	1100	800	2460.0	300	59	243
BA 200 LA8	15.0	730	32.8	0.77	87.3	196.23	1.9	6.1	950	1100	500	2880.0	300	60	243
BAH 225 M8**	22.0	735	51.3	0.71	90.5	285.85	2.1	6.4	2000	1000	350	7470.0	600	62	440
BAH 250 M8**	30.0	740	66.0	0.72	91.5	387.00	3.0	6.5	2000	-	250	11140.0	700	65	675
BAH 280 S8**	37.0	740	82.0	0.71	92.0	478.00	2.0	6.0	2000	-	190	12140.0	1000	65	750
BAH 280 M8**	45.0	740	96.0	0.73	92.5	581.00	1.8	5.8	2000	-	190	14640.0	1000	65	790

1. Motor characteristic values reported in the tables refer to continuous duty (S1), 50 Hz frequency, ambient temperature max. 40 °C, altitude up to 1000 m. above sea level operating condition.  
 2. DC brake is provided on request only on BA series motors. Brake current consumption values refer to a rated voltage of 3-phase 400V for AC brakes and single-phase 230V for DC brakes.  
 3. The table shows the sound pressure noise level, measured at one metre range from the motor according to the Acurve (ISO 1680). The shown noise levels refer to motor no-load operating condition and should be regarded with a tolerance of ± 3dB.  
 4. Max brake torque and Z<sub>0</sub> values refer to AC brake. Go to pag. 23 for

DC max brake torque values.  
 5. The expressed Z<sub>0</sub> values refers to AC Brake. Z<sub>0</sub> is the max number of no-load starts. It is meant for calculation purposes only, and is used to obtain the max number of starts with load according to the formula expressed at page 26. The number of starts with load (Z<sub>load</sub>) is indicative and it has to be operatively tested for confirmation. The use of Thermoprotectors is strongly recommended when the operative number of starts is close to the calculated Z<sub>load</sub>. It is necessary to verify the max permissible brake energy dissipation and the max permissible RPM.  
 6. The maximum brake torque for BAK 132 motors series is 120Nm.  
 7. Efficiency data at 50% and 75% of the full load are available in the specific

product documentation.  
 8. The international standard IEC 60034-30-1 doesn't specify efficiency classes for motors with rated power less than 0,12 kW.  
 9. The \*\* beside the motor type identifies non-standard motor powers for their frame size. Such motors might not meet the IE1 efficiency class. The \*\*\* beside the motor type identifies those motors that meet the IE2 efficiency class.  
 10. MGM keeps the data provided as up-to-date and correct as possible. Since the products are subject to changes and improvements, the data indicated cannot be considered binding. The data indicated must also be understood as being general in nature. For specific applications, please contact the MGM staff.

## technical data two speed motors - single winding

Motor type	Power (kW)	RPM	In (A) 400 V	cos φ	Tn (Nm)	Ts / Tn	Is / In	AC brake In (mA)	DC brake In (mA)	Z <sub>0</sub> (starts /hour)	Moment of inertia J <sub>x</sub> 10 <sup>-4</sup> Kg·m <sup>2</sup>	Max AC brake torque (Nm)	A-Sound pressure dB (A)	Weight (Kg)
2/4 pole														3000 / 1500 r.p.m.
BAD 71 A2/4	0.25	2820	0.75	0.73	0.85	2.2	3.8	90	110	8500	7.20	14	59	10.0
	0.18	1415	0.70	0.66	1.21	2.4	3.1							
BAD 71 B2/4	0.37	2820	1.00	0.77	1.25	2.3	4.7	90	110	7000	8.10	14	59	11.0
	0.25	1415	0.85	0.63	1.69	2.8	4.2							
BAD 80 A2/4	0.65	2790	1.80	0.81	2.22	2.0	4.1	140	150	3000	14.97	18	65	14.5
	0.45	1400	1.35	0.72	3.07	2.1	4.0							
BAD 80 B2/4	0.88	2800	2.2	0.80	3.00	2.0	4.9	140	150	3000	17.19	18	65	15.5
	0.62	1390	1.7	0.74	4.26	2.2	4.5							
BAD 90 SB2/4	1.3	2800	3.2	0.85	4.43	2.3	5.2	300	150	3000	26.15	38	72	20
	0.9	1420	2.3	0.73	6.05	2.5	5.0							
BAD 90 LA2/4	1.8	2800	4.4	0.83	6.14	2.6	5.6	300	150	2500	30.53	38	72	23
	1.2	1420	3.1	0.71	8.07	3.0	6.0							
BAD 90 LB2/4	2.2	2860	5.4	0.82	7.35	2.5	5.9	300	150	2500	34.57	38	72	24
	1.5	1430	3.8	0.73	10.02	3.0	6.0							
BAD 100 LA2/4	2.2	2875	5.0	0.85	7.31	2.3	6.0	300	150	1800	51.14	50	74	32
	1.5	1425	3.8	0.81	10.05	2.5	5.6							
BAD 100 LB2/4	3.1	2875	6.7	0.85	10.30	2.3	7.0	300	150	1700	60.07	50	74	36
	2.3	1425	5.2	0.82	15.41	2.4	6.5							
BAD 112 MB2/4	4.5	2880	9.2	0.88	14.92	2.4	7.0	280	470	900	125.7	80	75	45
	3.3	1400	6.9	0.86	22.51	2.8	6.5							
BAD 132 SB2/4	5.0	2940	10.9	0.81	16.24	2.8	8.0	580	680	400	277.0	150	75	78
	4.5	1450	9.3	0.84	29.64	2.6	7.5							
BAD 132 MA2/4	6.0	2940	11.7	0.88	19.49	2.6	8.0	580	680	400	352.0	150	75	87
	5.0	1450	10.0	0.85	32.93	2.5	7.5							
BAD 132 MB2/4	7.5	2940	16.0	0.82	24.36	2.4	8.0	580	680	400	352.0	150	75	87
	6.0	1450	12.2	0.83	39.52	2.5	7.5							
BAD 160 MA2/4	9.5	2870	20.0	0.89	31.61	2.8	7.5	1390	860	300	607.0	190	77	154
	8.0	1420	16.6	0.85	53.80	2.6	6.0							
BAD 160 MB2/4	11.0	2870	23.3	0.88	36.60	2.8	6.8	1390	860	300	683.0	190	77	154
	9.0	1420	18.7	0.85	60.53	2.6	6.0							
BAD 160 LA2/4	13.0	2890	26.1	0.91	42.96	2.8	7.0	1390	860	250	858.0	190	77	171
	11.0	1420	21.2	0.87	73.98	2.6	6.3							
BAD 180 LA2/4	17.0	2900	33.0	0.89	55.98	2.9	8.0	950	1100	100	1740.0	300	78	243
	14.0	1440	26.8	0.86	92.85	2.7	6.5							
BAD 180 LB2/4	20.5	2900	41.5	0.89	67.51	2.9	8.0	950	1100	100	1740.0	300	78	243
	17.0	1430	33.3	0.86	113.53	2.7	6.5							
BAD 200 LB2/4	24.0	2910	49.0	0.86	78.76	2.5	8.0	950	1100	70	1980.0	300	79	274
	20.0	1435	41.0	0.82	133.10	2.4	6.5							

1. Motor characteristic values reported in the tables refer to continuous duty (S1), 50 Hz frequency, ambient temperature max. 40 °C, altitude up to 1000 m, above sea level operating condition.  
 2. DC brake is provided on request only, on BA series motors. Brake current consumption values refer to a rated voltage of 3-phase 400V for AC brakes and single-phase 230V for DC brakes.  
 3. The table shows the sound pressure noise level, measured at one metre range from the motor according to the Acurve (ISO 1680). The shown noise levels refer to motor no-load operating condition and should

be regarded with a tolerance of ± 3dB.  
 4. Max brake torque and Z<sub>0</sub> values refer to AC brake. Go to pag. 23 for DC max brake torque values.  
 5. The expressed Z<sub>0</sub> values refers to AC Brake. Z<sub>0</sub> is the max number of no-load starts. It is meant for calculation purposes only, and is used to obtain the max number of starts with load according to the formula expressed at page 26. The number of starts with load (Z<sub>load</sub>) is indicative and it has to be operatively tested for confirmation. The use of Thermo-protectors is strongly recommended when the operative number of starts

is close to the calculated Z<sub>load</sub>. It is necessary to verify the max permissible brake energy dissipation and the max permissible RPM.  
 6. The maximum brake torque for BAK 132 motors series is 120Nm.  
 7. MGM keeps the data provided as up-to-date and correct as possible. Since the products are subject to changes and improvements, the data indicated cannot be considered binding. The data indicated must also be understood as being general in nature. For specific applications, please contact the MGM staff.

# technical data two speed motors - single winding



BA series

Motor type	Power (kW)	RPM	In (A) 400 V	cos φ	Tn (Nm)	Ts / Tn	Is / In	AC brake In (mA)	DC brake In (mA)	Z <sub>0</sub> (starts /hour)	Moment of inertia Jx 10 <sup>-4</sup> Kg·m <sup>2</sup>	Max AC brake torque (Nm)	A-Sound pressure dB (A)	Weight (Kg)	
4/8 pole														1500 / 750 r.p.m.	
BAD 71 A4/8	0.13 0.07	1385 700	0.35 0.45	0.82 0.60	0.90 0.96	1.6 1.8	3.0 2.0	90	110	12000 30000	10.08	14	45 43	10.5	
BAD 71 B4/8	0.18 0.09	1370 685	0.50 0.60	0.83 0.59	1.25 1.25	1.8 2.0	3.2 2.0	90	110	11000 30000	11.54	14	45 43	11.0	
BAD 71 C4/8	0.22 0.12	1370 685	0.60 0.75	0.83 0.59	1.53 1.67	1.6 1.8	3.0 2.0	90	110	10000 28000	12.35	14	45 43	12.0	
BAD 80 A4/8	0.25 0.18	1405 675	0.70 0.90	0.86 0.65	1.70 2.55	2.2 2.0	4.1 2.4	140	150	9000 22000	23.40	18	47 45	14.5	
BAD 80 B4/8	0.37 0.25	1405 675	0.85 1.15	0.86 0.65	2.51 3.54	2.2 2.0	4.1 2.4	140	150	9000 22000	27.21	18	47 45	15.5	
BAD 90 SA4/8	0.75 0.37	1350 695	1.70 1.80	0.85 0.53	5.31 5.08	1.8 2.3	3.9 2.7	300	150	10000 15000	35.93	38	55 46	20	
BAD 90 LB4/8	1.1 0.6	1390 695	2.7 3.0	0.82 0.53	7.56 8.24	2.0 2.5	4.5 2.7	300	150	8500 13000	52.62	38	55 46	24	
BAD 100 LB4/8	1.6 0.9	1395 700	3.6 3.5	0.87 0.58	10.95 12.28	2.0 2.2	5.0 3.5	300	150	4100 8500	99.19	50	57 49	35	
BAD 112 MB4/8	2.2 1.2	1440 720	4.8 4.6	0.86 0.57	14.59 15.92	2.5 3.1	5.5 4.1	280	470	3800 8000	168.3	80	61 52	45	
BAD 132 SB4/8	3.0 2.0	1440 720	6.6 5.8	0.85 0.64	19.90 26.53	2.2 2.5	6.0 5.0	580	680	1000 2000	325.0	150	62 55	73	
BAD 132 MA4/8	4.0 2.7	1440 720	8.8 7.8	0.85 0.64	26.53 35.81	2.2 2.5	6.0 5.0	580	680	1000 2000	413.0	150	62 55	80	
BAD 132 MB4/8	6.0 4.0	1440 720	13.0 11.6	0.85 0.64	39.79 53.06	2.2 2.5	6.0 5.0	580	680	1000 2000	611.0	150	62 55	118	
BAD 160 MB4/8	6.5 4.5	1470 730	15.1 13.3	0.80 0.62	42.23 58.87	2.6 2.4	8.0 6.5	1390	860	800 1450	1030.0	190	63 58	156	
BAD 160 LA4/8	9.5 6.0	1470 730	21.5 17.6	0.82 0.62	61.72 78.49	2.6 2.4	8.0 6.5	1390	860	750 1400	1360.0	190	63 58	174	
BAD 180 LA4/8	11.0 8.0	1470 730	22.0 19.2	0.85 0.70	71.46 105.38	2.8 2.4	7.5 7.0	950	1100	450 750	2460.0	300	64 59	243	
BAD 180 LB4/8	14.0 9.0	1465 730	27.1 22.3	0.87 0.68	91.26 117.74	2.7 2.5	7.5 7.0	950	1100	400 700	2460.0	300	64 59	243	
BAD 200 LA4/8	18.0 11.0	1430 710	36.3 27.2	0.88 0.71	120.21 147.96	2.8 2.6	7.5 8.0	950	1100	70 250	2880.0	300	66 60	293	
BAD 200 LB4/8	21.0 13.0	1425 710	41.6 31.7	0.88 0.70	140.74 174.86	2.6 2.4	7.0 6.5	950	1100	70 250	2880.0	300	66 60	293	
BAHD 225 S4/8	30.0 18.0	1470 730	56.6 43.2	0.87 0.70	195.00 235.60	2.5 2.4	7.5 7.0	1350	1500	60 200	6500.0	600	68 62	392	
BAHD 225 M4/8	35.0 25.0	1470 730	66.1 60.0	0.87 0.70	227.50 327.20	2.5 2.3	7.5 6.8	1350	1500	60 200	6900.0	600	68 62	440	
BAHD 250 M4/8	42.0 30.0	1470 730	75.0 65.0	0.89 0.75	272.00 392.00	1.9 1.7	5.5 4.0	2000	-	60 200	11680.0	700	70 65	800	

1. Motor characteristic values reported in the tables refer to continuous duty (S1), 50 Hz frequency, ambient temperature max. 40 °C, altitude up to 1000 m. above sea level operating condition.  
 2. DC brake is provided on request only, on BA series motors. Brake current consumption values refer to a rated voltage of 3-phase 400V for AC brakes and single-phase 230V for DC brakes.  
 3. The table shows the sound pressure noise level, measured at one metre range from the motor according to the Acurve (ISO 1680). The shown noise levels refer to motor no-load operating condition and should

be regarded with a tolerance of ± 3dB.  
 4. Max brake torque and Z<sub>0</sub> values refer to AC brake. Go to pag. 23 for DC max brake torque values.  
 5. The expressed Z<sub>0</sub> values refers to AC Brake. Z<sub>0</sub> is the max number of no-load starts. It is meant for calculation purposes only, and is used to obtain the max number of starts with load according to the formula expressed at page 26. The number of starts with load (Z<sub>load</sub>) is indicative and it has to be operatively tested for confirmation. The use of Thermoprotectors is strongly recommended when the operative number of starts

is close to the calculated Z<sub>load</sub>. It is necessary to verify the max permissible brake energy dissipation and the max permissible RPM.  
 6. The maximum brake torque for BAK 132 motors series is 120Nm.  
 7. MGM keeps the data provided as up-to-date and correct as possible. Since the products are subject to changes and improvements, the data indicated cannot be considered binding. The data indicated must also be understood as being general in nature. For specific applications, please contact the MGM staff.

## technical data two speed motors - two windings

Motor type	Power (kW)	RPM	In (A) 400 V	cos φ	Tn (Nm)	Ts / Tn	Is / In	AC brake In (mA)	DC brake In (mA)	Z <sub>0</sub> (starts /hour)	Moment of inertia Jx 10 <sup>-4</sup> Kgm <sup>2</sup>	Max AC brake torque (Nm)	A-Sound pressure dB (A)	Weight (Kg)
2/6 pole														3000 / 1000 r.p.m.
BADA 71 B2/6	0.25	2880	0.85	0.74	0.83	2.6	4.3	90	110	3600	8.10	14	59	11.0
	0.08	940	0.60	0.64	0.81	2.2	2.0							
BADA 71 C2/6	0.35	2880	1.05	0.75	1.16	2.6	5.0	90	110	3000	9.43	14	59	12.0
	0.10	940	0.60	0.59	1.02	2.2	2.3							
BADA 80 A2/6	0.37	2885	1.35	0.67	1.22	2.6	5.0	140	150	2000	14.97	18	65	14.5
	0.12	945	0.80	0.57	1.21	1.9	2.5							
BADA 80 B2/6	0.55	2885	1.75	0.67	1.82	2.6	5.0	140	150	2000	17.19	18	65	15.5
	0.18	945	1.05	0.57	1.82	1.9	2.5							
BADA 90 SA2/6	0.9	2875	2.10	0.86	2.99	2.5	5.0	300	150	1800	26.15	38	72	22.5
	0.3	950	1.15	0.65	3.02	2.2	2.5							
BADA 90 LA2/6	1.2	2875	2.80	0.86	3.99	2.5	5.0	300	150	1800	30.53	38	72	23
	0.4	950	1.55	0.65	4.02	2.2	2.5							
BADA 90 LB2/6	1.4	2890	3.2	0.86	4.63	2.7	5.0	300	150	1800	34.57	38	72	24
	0.5	940	1.8	0.55	5.08	2.5	3.0							
BADA 100 LA2/6	1.6	2810	3.7	0.85	5.44	2.6	5.4	300	150	1800	51.14	50	74	32
	0.6	900	1.9	0.68	6.37	2.3	3.4							
BADA 100 LB2/6	2.2	2800	4.8	0.90	7.50	2.6	5.4	300	150	1000	60.07	50	74	36
	0.8	910	2.5	0.67	8.40	2.3	3.4							
BADA 112 MB2/6	3.0	2870	6.4	0.86	9.98	3.0	7.0	280	470	1100	125.7	80	75	45
	1.0	950	3.2	0.61	10.05	3.2	4.5							
BADA 132 SB2/6	4.0	2880	8.9	0.85	13.26	3.0	7.0	580	680	350	277.0	150	75	78
	1.3	940	3.7	0.69	13.21	2.8	4.5							
BADA 132 MA2/6	5.5	2870	11.5	0.88	18.30	3.0	7.5	580	680	350	352.0	150	75	87
	1.8	940	5.1	0.69	18.29	2.8	4.5							
BADA 132 MB2/6	7.0	2870	14.9	0.88	23.29	3.0	7.5	580	680	350	432.0	150	75	98
	2.2	940	6.3	0.69	22.35	2.8	4.5							
BADA 160 MB2/6	8.0	2890	15.9	0.92	26.44	3.0	8.0	1390	860	250	683.0	190	77	154
	2.5	950	6.9	0.74	25.13	2.0	4.3							
BADA 160 LA2/6	11.0	2890	21.4	0.92	36.35	3.0	8.0	1390	860	250	858.0	190	77	171
	3.6	950	9.3	0.74	36.19	2.0	4.3							
BADA 180 LB2/6	16.0	2910	30.3	0.93	52.51	3.0	8.0	950	1100	100	1740.0	300	78	243
	6.5	960	16.0	0.72	64.66	2.4	5.0							

1. Motor characteristic values reported in the tables refer to continuous duty (S1), 50 Hz frequency, ambient temperature max. 40 °C, altitude up to 1000 m, above sea level operating condition.  
 2. DC brake is provided on request only, on BA series motors. Brake current consumption values refer to a rated voltage of 3-phase 400V for AC brakes and single-phase 230V for DC brakes.  
 3. The table shows the sound pressure noise level, measured at one metre range from the motor according to the Acurve (ISO 1680). The shown noise levels refer to motor no-load operating condition and should

be regarded with a tolerance of ± 3dB.  
 4. Max brake torque and Z<sub>0</sub> values refer to AC brake. Go to pag. 23 for DC max brake torque values.  
 5. The expressed Z<sub>0</sub> values refers to AC Brake. Z<sub>0</sub> is the max number of no-load starts. It is meant for calculation purposes only, and is used to obtain the max number of starts with load according to the formula expressed at page 26. The number of starts with load (Z<sub>load</sub>) is indicative and it has to be operatively tested for confirmation. The use of Thermo-protectors is strongly recommended when the operative number of starts

is close to the calculated Z<sub>load</sub>. It is necessary to verify the max permissible brake energy dissipation and the max permissible RPM.  
 6. The maximum brake torque for BAK 132 motors series is 120Nm.  
 7. MGM keeps the data provided as up-to-date and correct as possible. Since the products are subject to changes and improvements, the data indicated cannot be considered binding. The data indicated must also be understood as being general in nature. For specific applications, please contact the MGM staff.



Motor type	Power (kW)	RPM	In (A) 400 V	cos φ	Tn (Nm)	Ts / Tn	Is / In	AC brake In (mA)	DC brake In (mA)	Z <sub>0</sub> (starts /hour)	Moment of inertia Jx 10 <sup>-4</sup> Kg·m <sup>2</sup>	Max AC brake torque (Nm)	A-Sound pressure dB (A)	Weight (Kg)	
2/8 pole														3000 / 750 r.p.m.	
BADA 71 B2/8	0.25 0.06	2900 700	0.85 0.55	0.69 0.54	0.82 0.82	2.8 1.8	4.0 1.5	90	110	3600 25000	9.10	14	59 43	11.0	
BADA 71 C2/8	0.35 0.07	2900 700	1.05 0.75	0.70 0.52	1.15 0.96	2.5 2.2	4.3 1.6	90	110	3000 22000	9.43	14	65 43	12.0	
BADA 80 A2/8	0.37 0.09	2885 690	1.35 0.70	0.67 0.54	1.22 1.25	2.3 1.8	5.0 1.7	140	150	2000 20000	14.97	18	65 45	14.5	
BADA 80 B2/8	0.55 0.12	2885 690	1.75 0.90	0.67 0.54	1.82 1.66	2.3 2.0	5.0 1.7	140	150	2000 20000	17.19	18	72 45	15.5	
BADA 90 SB2/8	0.75 0.18	2800 610	1.90 1.05	0.77 0.65	2.56 2.82	3.0 2.1	5.1 1.9	300	150	1800 18000	26.15	38	72 46	22.5	
BADA 90 LA2/8	1.10 0.25	2800 640	2.70 1.45	0.81 0.58	3.75 3.73	3.0 2.1	5.1 1.9	300	150	1800 17000	30.53	38	72 46	23.0	
BADA 90 LB2/8	1.3 0.3	2820 640	3.10 1.75	0.81 0.58	4.40 4.48	3.2 2.4	5.7 2.0	300	150	1800 16000	34.57	38	72 46	24.0	
BADA 100 LA2/8	1.6 0.4	2810 660	3.7 2.0	0.85 0.58	5.44 5.79	2.7 2.0	5.3 2.2	300	150	1800 16000	51.14	50	74 49	32	
BADA 100 LB2/8	2.2 0.5	2800 660	4.8 2.5	0.90 0.59	7.50 7.23	2.8 2.3	5.7 2.3	300	150	1000 10500	60.07	50	74 49	36	
BADA 112 MB2/8	3.0 0.8	2860 690	6.3 3.5	0.87 0.63	10.02 11.07	3.3 2.6	7.5 3.2	280	470	1100 9000	125.7	80	75 52	45	
BADA 132 SB2/8	4.0 1.1	2880 680	8.9 4.0	0.85 0.60	13.26 15.45	3.0 1.9	7.0 3.3	580	680	430 1800	277.0	150	75 55	78	
BADA 132 MA2/8	5.5 1.5	2870 680	11.5 5.6	0.88 0.59	18.30 21.07	3.0 2.0	7.5 3.0	580	680	400 1800	352.0	150	75 55	87	
BADA 132 MB2/8	7.0 1.8	2870 680	14.9 7.3	0.88 0.59	23.29 25.28	3.0 2.0	7.5 3.0	580	680	400 1800	432.0	150	75 55	98	
BADA 160 MB2/8	8.0 2.2	2880 705	16.7 7.6	0.91 0.65	26.53 29.80	3.0 1.9	8.0 3.3	1390	860	300 1500	683.0	190	77 58	154	
BADA 160 LA2/8	11.0 3.0	2880 710	21.5 10.2	0.92 0.65	36.48 40.35	3.0 1.9	8.0 3.3	1390	860	300 1500	858.0	190	77 58	171	
BADA 180 LB2/8	16.0 4.0	2915 715	30.0 11.5	0.93 0.66	52.42 53.43	3.0 1.9	8.0 3.3	950	1100	100 300	1740.0	300	79 59	243	
BADA 200 LB2/8	18.5 4.5	2915 715	35.0 13.5	0.93 0.66	60.61 60.10	3.0 1.9	8.0 3.3	950	1100	100 300	2030.0	300	79 59	255	

1. Motor characteristic values reported in the tables refer to continuous duty (S1), 50 Hz frequency, ambient temperature max. 40 °C, altitude up to 1000 m. above sea level operating condition.  
 2. DC brake is provided on request only, on BA series motors. Brake current consumption values refer to a rated voltage of 3-phase 400V for AC brakes and single-phase 230V for DC brakes.  
 3. The table shows the sound pressure noise level, measured at one metre range from the motor according to the Acurve (ISO 1680). The shown noise levels refer to motor no-load operating condition and should

be regarded with a tolerance of ± 3dB.  
 4. Max brake torque and Z<sub>0</sub> values refer to AC brake. Go to pag. 23 for DC max brake torque values.  
 5. The expressed Z<sub>0</sub> values refers to AC Brake. Z<sub>0</sub> is the max number of no-load starts. It is meant for calculation purposes only, and is used to obtain the max number of starts with load according to the formula expressed at page 26. The number of starts with load (Z<sub>load</sub>) is indicative and it has to be operatively tested for confirmation. The use of Thermoprotectors is strongly recommended when the operative number of starts

is close to the calculated Z<sub>load</sub>. It is necessary to verify the max permissible brake energy dissipation and the max permissible RPM.  
 6. The maximum brake torque for BAK 132 motors series is 120Nm.  
 7. MGM keeps the data provided as up-to-date and correct as possible. Since the products are subject to changes and improvements, the data indicated cannot be considered binding. The data indicated must also be understood as being general in nature. For specific applications, please contact the MGM staff.

# technical data two speed motors - two windings

Motor type	Power (kW)	RPM	In (A) 400 V	cos φ	Tn (Nm)	Ts / Tn	Is / In	AC brake In (mA)	DC brake In (mA)	Z <sub>0</sub> (starts /hour)	Moment of inertia Jx 10 <sup>-4</sup> Kgm <sup>2</sup>	Max AC brake torque (Nm)	A-Sound pressure dB (A)	Weight (Kg)	
4/6 pole													1500 / 1000 r.p.m.		
BADA 71 C4/6	0.18	1415	0.60	0.76	1.21	1.9	3.0	90	110	7500	12.35	14	45	12.0	
	0.11	930	0.50	0.66	1.13	2.0	2.3								
BADA 80 A4/6	0.25	1430	0.85	0.79	1.67	2.2	4.3	140	150	7000	23.40	18	47	14.5	
	0.18	940	0.80	0.71	1.83	1.8	3.0								
BADA 80 B4/6	0.37	1430	1.05	0.79	2.47	2.2	4.3	140	150	7000	27.21	18	47	15.5	
	0.25	940	0.95	0.71	2.54	1.8	3.0								
BADA 90 SA4/6	0.55	1420	1.60	0.78	3.70	1.9	3.8	300	150	6000	35.93	38	55	20.0	
	0.37	950	1.45	0.62	3.72	2.1	3.3								
BADA 90 LB4/6	0.75	1420	2.20	0.78	5.04	2.0	3.8	300	150	5500	46.08	38	55	23.0	
	0.55	950	1.9	0.62	5.53	2.1	3.3								
BADA 100 LA4/6	1.1	1445	3.0	0.76	7.27	2.0	5.3	300	150	2000	86.40	50	57	33.0	
	0.8	955	2.4	0.71	8.00	2.1	4.4								
BADA 100 LB4/6	1.5	1440	3.9	0.75	9.95	2.0	5.2	300	150	1800	99.19	50	57	35.0	
	1.1	950	3.3	0.68	11.06	2.1	4.4								
BADA 112 MB4/6	2.0	1385	4.4	0.88	13.79	2.6	5.3	280	470	2600	168.3	80	61	45	
	1.3	930	3.5	0.75	13.35	2.1	4.4								
BADA 132 SB4/6	2.2	1440	5.1	0.78	14.59	2.9	7.0	580	680	600	346.0	150	62	78	
	1.5	950	4.4	0.69	15.08	2.6	5.5								
BADA 132 MA4/6	3.0	1440	6.4	0.81	19.90	2.7	7.0	580	680	600	401.0	150	62	83	
	2.2	950	6.0	0.71	22.12	2.4	5.0								
BADA 132 MB4/6	3.7	1440	8.2	0.78	24.54	2.9	7.0	580	680	500	508.0	150	62	94	
	2.5	950	7.0	0.69	25.13	2.6	5.5								
BADA 160 MB4/6	5.5	1390	11.1	0.93	37.79	2.5	5.8	1390	860	400	943.0	190	63	156	
	3.7	940	8.9	0.81	37.59	2.3	5.2								
BADA 160 LB4/6	7.5	1390	15.2	0.93	51.53	2.5	6.0	1390	860	400	1240.0	190	63	174	
	5.0	940	12.2	0.81	50.80	2.3	5.2								
BADA 180 LB4/6	13.0	1440	24.6	0.91	86.22	2.95	7.0	950	1100	350	2070.0	300	64	243	
	8.8	950	18.9	0.82	88.46	2.00	6.0								

1. Motor characteristic values reported in the tables refer to continuous duty (S1), 50 Hz frequency, ambient temperature max. 40 °C, altitude up to 1000 m, above sea level operating condition.  
 2. DC brake is provided on request only, on BA series motors. Brake current consumption values refer to a rated voltage of 3-phase 400V for AC brakes and single-phase 230V for DC brakes.  
 3. The table shows the sound pressure noise level, measured at one metre range from the motor according to the Acurve (ISO 1680). The shown noise levels refer to motor no-load operating condition and should

be regarded with a tolerance of ± 3dB.  
 4. Max brake torque and Z<sub>0</sub> values refer to AC brake. Go to pag. 23 for DC max brake torque values.  
 5. The expressed Z<sub>0</sub> values refers to AC Brake. Z<sub>0</sub> is the max number of no-load starts. It is meant for calculation purposes only, and is used to obtain the max number of starts with load according to the formula expressed at page 26. The number of starts with load (Z<sub>load</sub>) is indicative and it has to be operatively tested for confirmation. The use of Thermoprotectors is strongly recommended when the operative number of starts

is close to the calculated Z<sub>load</sub>. It is necessary to verify the max permissible brake energy dissipation and the max permissible RPM.  
 6. The maximum brake torque for BAK 132 motors series is 120Nm.  
 7. MGM keeps the data provided as up-to-date and correct as possible. Since the products are subject to changes and improvements, the data indicated cannot be considered binding. The data indicated must also be understood as being general in nature. For specific applications, please contact the MGM staff.

# technical data two speed motors - two windings



BA series

Motor type	Power (kW)	RPM	In (A) 400 V	cos φ	Tn (Nm)	Ts / Tn	Is / In	AC brake In (mA)	DC brake In (mA)	Z <sub>0</sub> (starts /hour)	Moment of inertia Jx 10 <sup>-4</sup> Kg·m <sup>2</sup>	Max AC brake torque (Nm)	A-Sound pressure dB (A)	Weight (Kg)
4/12 pole	<b>S3 40%</b>										1500 / 500 r.p.m.			
BADA 80 A4/12	0.25 0.05	1425 435	0.85 0.60	0.77 0.63	1.68 1.10	1.8 1.9	3.7 1.6	140	110	7000 24000	23.40	18	47 43	14.5
BADA 80 B4/12	0.37 0.07	1425 435	1.05 0.75	0.77 0.63	2.48 1.54	1.8 1.9	3.7 1.6	140	110	7000 24000	27.21	18	47 43	15.5
BADA 90 SA4/12	0.40 0.13	1360 380	1.25 1.05	0.73 0.59	2.81 3.27	2.5 2.0	3.5 1.6	300	150	5500 30000	35.93	38	55 44	20.0
BADA 90 LA4/12	0.55 0.18	1400 400	1.65 1.20	0.76 0.64	3.75 4.30	2.5 1.8	3.5 1.6	300	150	5500 30000	46.08	38	55 44	23.0
BADA 90 LB4/12	0.75 0.22	1370 400	2.05 1.60	0.76 0.65	5.23 5.25	2.5 2.0	3.5 1.6	300	150	5000 28000	52.62	38	55 44	24.0
BADA 100 LA4/12	0.90 0.25	1440 450	2.3 2.1	0.76 0.50	5.97 5.31	2.2 1.8	5.3 1.7	300	150	4400 15000	87.40	50	57 47	33.0
BADA 100 LB4/12	1.10 0.35	1440 450	2.8 2.6	0.76 0.50	7.30 7.43	2.2 1.8	5.3 1.7	300	150	2100 13000	99.19	50	57 47	35.0
BADA 112 MB4/12	1.50 0.45	1420 440	3.4 2.4	0.84 0.55	10.09 9.77	2.2 2.0	6.0 2.2	280	470	2600 15000	168.3	80	61 50	45.0
BADA 132 SA4/12	2.50 0.80	1440 440	5.4 3.8	0.81 0.53	16.58 17.36	2.7 1.6	7.0 2.4	580	680	800 2200	346.0	150	62 58	78.0
BADA 132 MA4/12	3.0 1.0	1440 440	6.4 4.5	0.81 0.53	19.90 21.70	2.7 1.6	7.0 2.4	580	680	800 2200	401.0	150	62 58	83
BADA132 MB4/12	4.0 1.3	1440 440	8.5 5.9	0.81 0.55	26.53 28.22	2.7 1.6	7.0 2.4	580	680	800 2200	508.0	150	62 58	94
BADA 160 MB4/12	4.8 1.6	1425 455	10.0 7.2	0.89 0.57	32.17 33.58	2.8 2.0	7.5 3.0	1390	860	600 1700	943.0	190	63 61	156
BADA 160LB4/12	7.3 2.4	1410 445	15.2 10.1	0.90 0.61	49.44 51.51	2.8 2.0	7.0 3.0	1390	860	600 1700	1240.0	190	63 61	174

1. Motor characteristic values reported in the tables refer to 50 Hz frequency, ambient temperature max. 40 °C, altitude up to 1000 m. above sea level operating condition.  
 2. DC brake is provided on request only, on BA series motors. Brake current consumption values refer to a rated voltage of 3-phase 400V for AC brakes and single-phase 230V for DC brakes.  
 3. The table shows the sound pressure noise level, measured at one metre range from the motor according to the Acurve (ISO 1680). The shown noise levels refer to motor no-load operating condition and should

be regarded with a tolerance of ± 3dB.  
 4. Max brake torque and Z<sub>0</sub> values refer to AC brake. Go to pag. 23 for DC max brake torque values.  
 5. The expressed Z<sub>0</sub> values refers to AC Brake. Z<sub>0</sub> is the max number of no-load starts. It is meant for calculation purposes only, and is used to obtain the max number of starts with load according to the formula expressed at page 26. The number of starts with load (Z<sub>load</sub>) is indicative and it has to be operatively tested for confirmation. The use of Thermoprotectors is strongly recommended when the operative number of starts

is close to the calculated Zload. It is necessary to verify the max permissible brake energy dissipation and the max permissible RPM.  
 6. The maximum brake torque for BAK 132 motors series is 120Nm.  
 7. MGM keeps the data provided as up-to-date and correct as possible. Since the products are subject to changes and improvements, the data indicated cannot be considered binding. The data indicated must also be understood as being general in nature. For specific applications, please contact the MGM staff.

# technical data two speed motors - two windings

Motor type	Power (kW)	RPM	In (A) 400 V	cos φ	Tn (Nm)	Ts / Tn	Is / In	AC brake In (mA)	DC brake In (mA)	Z <sub>0</sub> (starts /hour)	Moment of inertia Jx 10 <sup>-4</sup> Kg·m <sup>2</sup>	Max AC brake torque (Nm)	A-Sound pressure dB (A)	Weight (Kg)
2/12 pole		<b>S3 40%</b>										3000 / 500 r.p.m.		
BADA 80 B2/12	0.45 0.07	2840 435	1.35 0.70	0.76 0.63	1.51 1.54	1.9 1.9	4.9 1.4	140	150	1700 24000	27.21	18	65 43	15.5
BADA 90 SB2/12	0.75 0.11	2800 400	2.10 1.05	0.82 0.61	2.56 2.63	3.0 2.0	5.2 1.4	300	150	1800 20000	26.15	38	72 44	22.5
BADA 90 LA2/12	1.10 0.15	2800 400	2.80 1.35	0.82 0.63	3.75 3.58	3.2 2.1	5.4 1.4	300	150	1800 20000	30.53	38	72 44	23
BADA 100 LB2/12	1.85 0.25	2850 410	4.1 2.2	0.87 0.52	6.20 5.82	3.0 2.2	6.3 1.5	300	150	1100 11000	60.07	50	73 47	36
BADA 112 MB2/12	3.00 0.45	2855 430	6.5 3.2	0.86 0.49	10.04 9.99	3.0 2.1	6.7 1.8	280	470	1200 10000	125.7	80	73 50	45
BADA 132 SB2/12	4.00 0.65	2880 450	8.9 4.8	0.85 0.56	13.26 13.79	3.0 1.8	7.0 1.6	580	680	350 2200	277.7	150	73 55	78
BADA 132 MA2/12	5.50 0.90	2870 450	11.5 6.7	0.88 0.56	18.30 19.10	3.0 1.8	7.5 1.6	580	680	350 2200	352.0	150	73 55	87
BADA 132 MB2/12	7.00 1.10	2880 450	15.7 8.5	0.85 0.56	23.21 23.34	3.0 1.8	7.5 1.6	580	680	350 2200	432.0	150	73 55	98
BADA 160 MB2/12	8.00 1.30	2890 470	15.9 9.5	0.92 0.42	26.44 26.41	3.0 2.0	8.0 2.1	1390	860	250 1200	683.0	190	74 58	154
BADA 160 LA2/12	11.00 1.80	2890 470	21.4 12.8	0.92 0.42	36.35 36.57	3.0 2.0	8.0 2.1	1390	860	250 1200	858.0	190	74 58	171
BADA 180 LB2/12	16.00 2.60	2910 470	30.6 12.2	0.93 0.46	52.51 52.83	3.0 1.8	8.0 2.0	950	1100	200 1000	1740.0	300	78 59	243

## Hoisting motors 4/16 pole

Motor type	Power (kW)	RPM	In (A) 400 V	AC brake In (mA)
Service duty S4 (40% 4 pole - 25% 16 pole)				1500 / 375 r.p.m.
BAPKDA 132 MA4/16	2.8 / 0.7	1450 / 350	7.3 / 5.1	580
BAPKDA 132 MB4/16	4.0 / 1.1	1450 / 350	10.8 / 7.6	580
BAPDA 160 MA4/16	5.5 / 1.3	1420 / 335	11.6 / 8.0	1390
BAPDA 160 MB4/16	7.3 / 1.8	1420 / 330	16.2 / 11.4	1390
BAPDA 160 LB4/16	10.0 / 2.5	1420 / 330	22.2 / 15.9	1390
BAPDA 180 LA4/16	13.2 / 3.0	1450 / 350	25.0 / 21.7	950
BAPDA 200 LB4/16	16.0 / 4.0	1450 / 350	31.5 / 27.4	950
BAHPDA 225 S4/16	19.0 / 4.8	1470 / 360	38.2 / 28.0	2000
BAHPDA 225 M4/16	24.0 / 6.0	1470 / 360	47.3 / 34.7	2000
BAHPDA 250 M4/16	30.0 / 7.5	1465 / 360	58.7 / 43.3	2000
BAHPDA 280 S4/16	45.0 / 10.0	1475 / 365	83.0 / 75.0	2000
BAHPDA 280 M4/16	55.0 / 12.0	1475 / 365	100.0 / 90.0	2000

1. Motor characteristic values reported in the tables refer to 50 Hz frequency, ambient temperature max. 40 °C, altitude up to 1000 m. above sea level operating condition.  
 2. DC brake is provided on request only, on BA series motors. Brake current consumption values refer to a rated voltage of 3-phase 400V for AC brakes and single-phase 230V for DC brakes.  
 3. The table shows the sound pressure noise level, measured at one metre range from the motor according to the Acurve (ISO 1680). The shown noise levels refer to motor no-load operating condition and should

be regarded with a tolerance of ± 3dB.  
 4. Max brake torque and Z<sub>0</sub> values refer to AC brake. Go to pag. 23 for DC max brake torque values.  
 5. The expressed Z<sub>0</sub> values refers to AC Brake. Z<sub>0</sub> is the max number of no-load starts. It is meant for calculation purposes only, and is used to obtain the max number of starts with load according to the formula expressed at page 26. The number of starts with load (Z<sub>load</sub>) is indicative and it has to be operatively tested for confirmation. The use of Thermoprotectors is strongly recommended when the operative number of starts

is close to the calculated Z<sub>load</sub>. It is necessary to verify the max permissible brake energy dissipation and the max permissible RPM.  
 6. The maximum brake torque for BAK 132 motors series is 120Nm.  
 7. MGM keeps the data provided as up-to-date and correct as possible. Since the products are subject to changes and improvements, the data indicated cannot be considered binding. The data indicated must also be understood as being general in nature. For specific applications, please contact the MGM staff.

## Starting and braking time

Starting current for an asynchronous motor is always much higher than the nominal current. When the starting time is excessively long, there are electromechanical disturbances and higher temperatures on the windings, damaging the motor. For information on maximum starting time allowed for each type of motor, please contact MGM. An indicative value for starting time  $t_s$  (expressed in seconds) and the angle of rotation  $\varphi_a$  (expressed in radians) can be obtained as follows:

$$t_s = \frac{(J_{mot} + J_{app}) \cdot n}{9.55 (T - T_{load})} \quad \varphi_a = \frac{t_s \cdot n}{19.1}$$

Where  $J_{app}$  (Kgm<sup>2</sup>) is the moment of inertia referred to the motor shaft,  $M_{load}$  (Nm) is the opposing torque to the motor,  $J_{mot}$  (Kgm<sup>2</sup>) is the moment of inertia of the motor,  $n$  (RPM) is the rated motor RPM,  $T$  is the average starting torque,  $T=(0,8-0,9)T_s$  (see the technical data table for  $J_{mot}$ ,  $n$  and  $t_s$  of the selected motor).

An indicative braking time  $t_f$  (s) can be calculated as follows:

$$\frac{J_{tot} \cdot n}{9.55 (T_b \pm T_{load})} + \frac{t_B}{1000}$$

### Brake electrical reaction time $t_B$ (ms)

Motor type	AC Brake	DC Brake (Standard)	DC Brake (Quick)
BA 71-80-90	7	80	20
BA 100-112	9	80	30
BA 132-160	12	85	30
BA 180-200	12	90	30
BAH 225	14	100	35
BAH 250	14	-	-
BAH 280	14	-	-
BAH 315	14	-	-

- where:
- $J_{tot}$  total moment of inertia at the motor shaft (Kgm<sup>2</sup>)
  - $n$  motor RPM (min<sup>-1</sup>)
  - $T_b$  brake torque (Nm)
  - $T_{load}$  resisting load torque (Nm) with + sign if matches the brake torque, or - sign if opposite
  - $t_B$  brake electrical reaction time (ms)

The reported  $t_B$  times are valid only if the motor is connected with the brake in parallel. In case the brake is supplied separately, the  $t_B$  time has to be cut by 30-50%. This calculation gives an approximative indication. Please contact MGM for further information.

## Brake disc linings wear

The indicative number of start/stop ( $N_{int}$ ) that a brake motor can carry between two successive air gap adjustments can be calculated with the following formula:

$$N_{int} = E_r / W_f$$

where  $W_f$  (J) is the energy dissipated during a single braking action and  $E_r$  (MJ) is the value that can be obtained from the table below. The following formula can be used to calculate the  $W_f$  (J):

$$W_f (J) = 1/2 I_{tot} \omega^2$$

where  $I_{tot}$  is the total moment of inertia (the motor moment of inertia plus the inertia to the motor shaft) and  $\omega$  (rad/s) is the motor rotation speed. The table shows the  $E_r$  (MJ) values for the different frame sizes on the BA series motors with AC brake, BA series motors with DC brake, and BM series motors (DC brake standard). Multiply the values in the table by 0.5 in order to calculate the  $E_r$  (MJ) values for BAPV motors and take into account the additional moment of inertia introduced by the flywheel. Even for BMPV series motors please consider the additional moment of inertia introduced by the flywheel.

Motor type	71	80	90	100	112	132	160	180	200	225
BA with AC brake	56	80	95	105	130	200	290	385	385	462
BA with DC brake	34	48	57	63	78	120	174	231	231	277
BM	15	23	29	36	45	60	70	110	110	190

Values shown in the table must be considered as indicative only. In fact, the wear of the brake disc linings is influenced by various factors (brakes cycling, energy dissipated at each braking, environment condition, brake torque, etc.). The friction surfaces temperature grows both with the frequency of the braking actions and with the moment of inertia applied to the motor. When brake friction surface temperature is high, brake disc linings wear increases, causing a variation in the stopping times.

On BA series motors the cooling fan is located between the motor body and the brake. This arrangement allows cooling down both the motor frame and the brake friction surface resulting in a reduced brake disc lining wear and in steadier stopping times.

The brake lining wear is greater during the braking in period (a few thousand stops). This aspect has to be taken into consideration when experimentally calculating the interval time required between two consecutive air gap adjustments.

# BA-BAX and BAH-BAHX dimensions

Size	71	80	90S	90L	100L	112M	132S	132M	160M	160L	180L	200L	225S	225M	250M	280S	280M	315S	315M
	BA-BAX										BAH-BAHX								
<b>A</b>	112	125	140	140	160	190	216	216	254	254	279	318	356	356	406	457	457	508	508
<b>B</b>	90	100	100	125	140	140	140	178	210	254	279	305	286	311	349	368	419	406	457
<b>C</b>	45	50	56	56	63	70	89	89	108	108	121	133	149	149	168	190	190	216	216
<b>D*</b>	14	19	24	24	28	28	38	38	42	42	48	55	60	60	65	75	75	80	80
<b>d</b>	M5	M6	M8	M8	M10	M10	M12	M12	M16	M16	M16	M20	M20	M20	M20	M20	M20	M20	M20
<b>E*</b>	30	40	50	50	60	60	80	80	110	110	110	110	140	140	140	140	140	170	170
<b>Fa</b>	9.5	11.5	11.5	11.5	14.5	14.5	14.5	14.5	18.5	18.5	18.5	18.5	18.5	18.5	18.5	18.5	18.5	24	24
<b>Fb</b>	M6	M6	M8	M8	M8	M8	M10	M10											
<b>f</b>	5	6	8	8	8	8	10	10	12	12	14	16	18	18	18	20	20	22	22
<b>g</b>	11	15.5	20	20	24	24	33	33	37	37	42.5	49	53	53	58	67.5	67.5	71	71
<b>H</b>	71	80	90	90	100	112	132	132	160	160	180	200	225	225	250	280	280	315	315
<b>h</b>	5	6	7	7	7	7	8	8	8	8	9	10	11	11	11	12	12	14	14
<b>I</b>	7	10	10	10	12	12	12	12	14.5	14.5	15	18.5	18	18	24	24	24	28	28
<b>K</b>	10.5	14	14	14	16	16	22	22	24	24	24	30	33	33	33	24	24	45	45
<b>L</b>	148	162	171	196	217	229													
<b>L1</b>	184	194	207	232	254	262	294	339	373	395	420	446	530	530	569	708	734	754.5	780
<b>Ma</b>	130	165	165	165	215	215	265	265	300	300	300	350	400	400	500	500	500	600	600
<b>Mb</b>	85	100	115	115	130	130	165	165											
<b>Na</b>	110	130	130	130	180	180	230	230	250	250	250	300	350	350	450	450	450	550	550
<b>Nb</b>	70	80	95	95	110	110	130	130											
<b>Oa</b>	3.5	3.5	3.5	3.5	4	4	4	4	5	5	5	5	5	5	5	5	5	6	6
<b>Ob</b>	2.5	3	3	3	3.5	3.5	3.5	3.5											
<b>Pa</b>	160	200	200	200	250	250	300	300	350	350	350	400	450	450	550	550	550	660	660
<b>Pb</b>	105	120	140	140	160	160	200	200											
<b>Q</b>	344	380	412	436	490	505	600	638	745	789	863	890	1032	1032	1135	1221	1275	1379	1430
<b>Q<sub>BAF/BAPV</sub></b>	368	403	436	460	511	531	628	666	778	822	907	932							
<b>R</b>	80	80	98.5	98.5	98.5	98.5													
<b>R1</b>	135	135	170	170	170	170	199	199	268	268	268	268	327	327	327	504	504	504	504
<b>S</b>	10	12	12	12	14	14	15	15	15	15	15	15	20	20	18	18	18	22	22
<b>V</b>	8	9.5	10.5	10.5	12.5	13.5	16	16	21	21	24	24	32	32	32	40	40	46	46
<b>W</b>	105	113	127	127	138	158													
<b>W1</b>	121	130	148	148	162	176	210	210	246	246	266	266	341	341	361	458	458	493	493
<b>Y</b>	145	160	180	180	196	218	265	265	324	324	357	357	430	430	493	493	493	493	493
<b>Z</b>	75	75	98.5	98.5	98.5	98.5													
<b>Z1</b>	86	86	112	112	112	112	151	151	167	167	167	167	202	202	202	282	282	282	282

\* 225S-225M 2 pole D=55 E=110, 250M 2 pole D=60 E=140, 280S-280M 2 pole D=65 E=140, 315 2 pole D=65 E=110

\*\* The brake motors type BAX200 have the following dimensions: R1=327, L1=511, Q=911, Z1=202, W1=304

### Notes

Q<sub>BAF</sub> is the Q dimension for BAF series

Q<sub>BAPV</sub> is the Q dimension for BAPV series

Cable glands are M 20 on size 71 up to 80

M 25 on size 90 up to 112

M 32 on size 132

M 40 on size 160 up to 200

M 50 on size 225/250

Motors with the terminal board box on the side (left or right) are available on request. Please contact MGM for further information.

**B5**

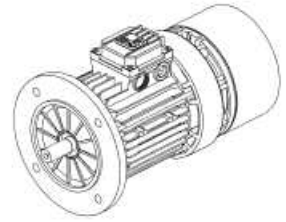
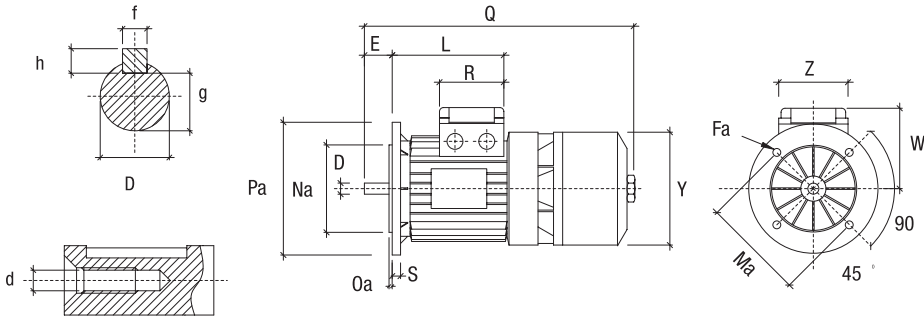

**B14**

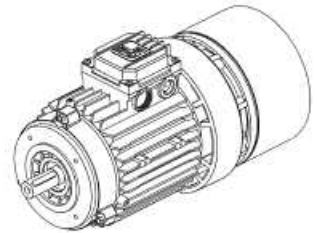
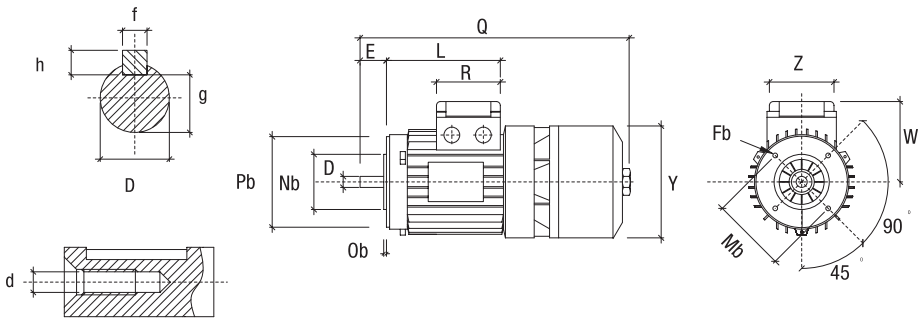

**B3**

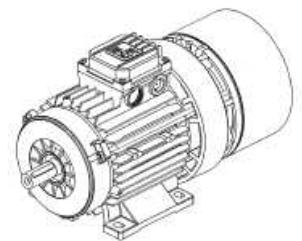
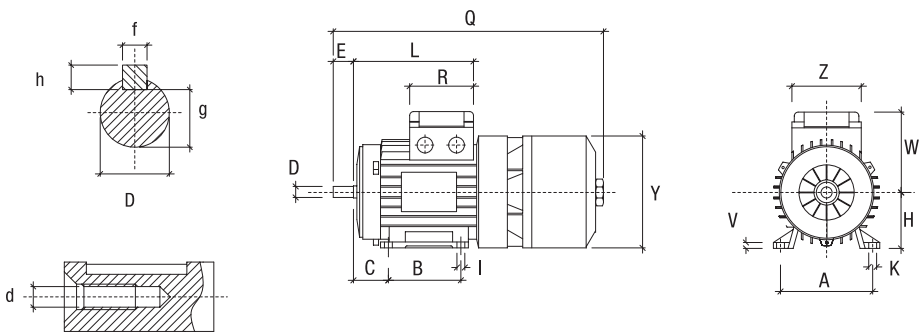

**160-315 B3**

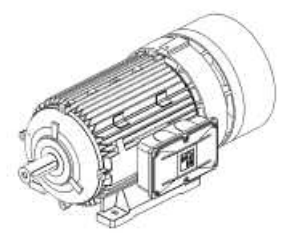
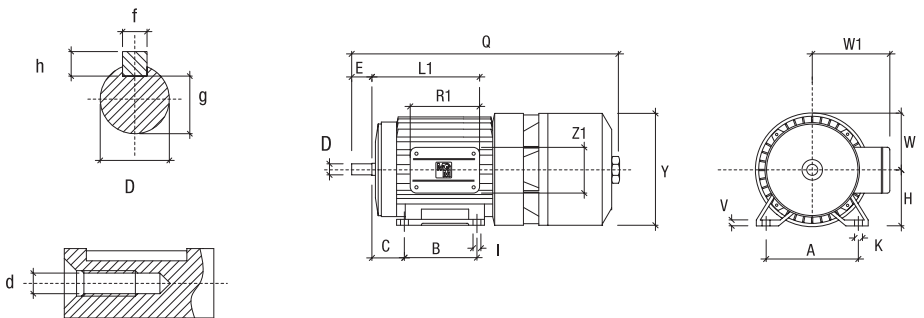

**double terminal board box**

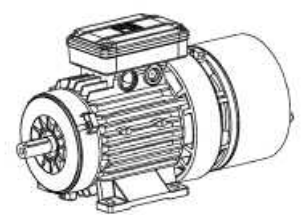
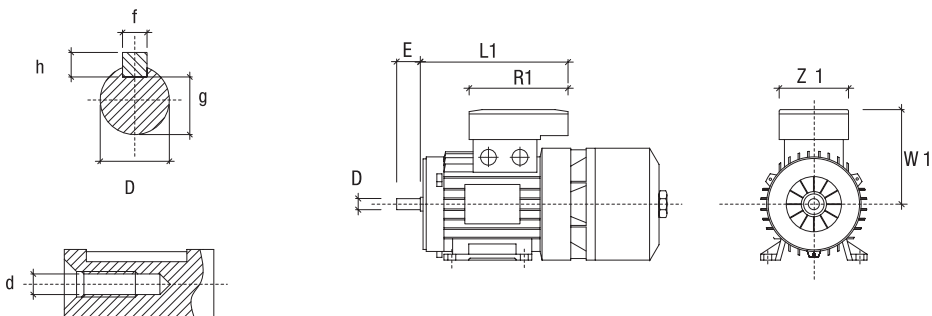

**B5**

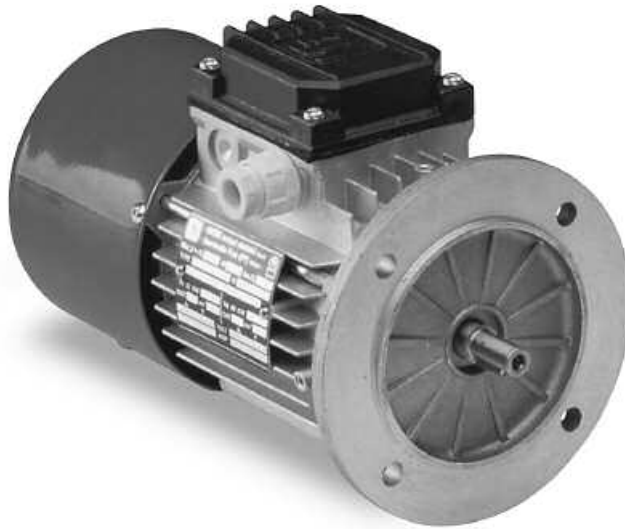

**B14**



**B3**

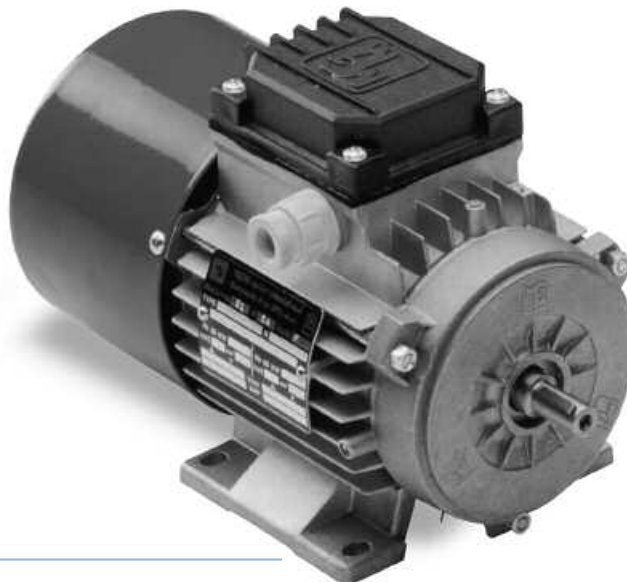



**BM series**

BM series consists of three phase, asynchronous brake motors. BM series range starts from 56 up to 225 frame size. As standard the brake is DC voltage supply with a built-in rectifier fitted inside the terminal box. The rectifier is provided with over-voltage protection devices. Two different types of rectifier wiring can be chosen according to two different brake intervention time. The motor brakes in case of power supply failure. The brake torque remains the same in both directions of rotation and the motor brakes without shaft axial sliding.

BM series is designed in order to have a braking action as quiet as possible. BM series motors tolerate a high overloading rate and are capable to withstand overheating so to guarantee best reliability also under tough operating conditions. All MGM motors have been designed to be controlled by inverters. The motor winding insulation is class F, while class H is available on request. Motor construction type is totally enclosed externally cooled (TEFC) and IP54 enclosure (IP55, IP56, IP65 and IP66 are available on request).

Motors up to 132 frame size are fitted as standard with a hexagonal hole on the shaft the at non drive end, to allow manual rotation, even if power is off. On request, BM series motors can be provided with a side manual brake release lever. The brake disc lining material is asbestos free and the lining mixture is formulated to have a high friction coefficient and a long life. BM series motor frame is made of die cast, light metal on motors up to 132 size and the terminal board box, provided with cable glands and plugs, is positioned 180° above the motor support feet. The frame is made of cast iron starting from 160 frame size and the terminal box is located on the right side (drive-end view). On IM B3 mounting (foot mounted) feet are frame integrated (they are not simply attached to the frame) as standard and it makes the motor very sturdy. This feature is very important for those applications where the motor is much stressed during the starts and stops. Shields and flanges are made of aluminium on motors up to 90 frame size, and of cast iron on motors of 100 frame size and above.

BM series main features are the low braking noise, gradual acceleration during the motor start and stop and reduced overall dimensions.

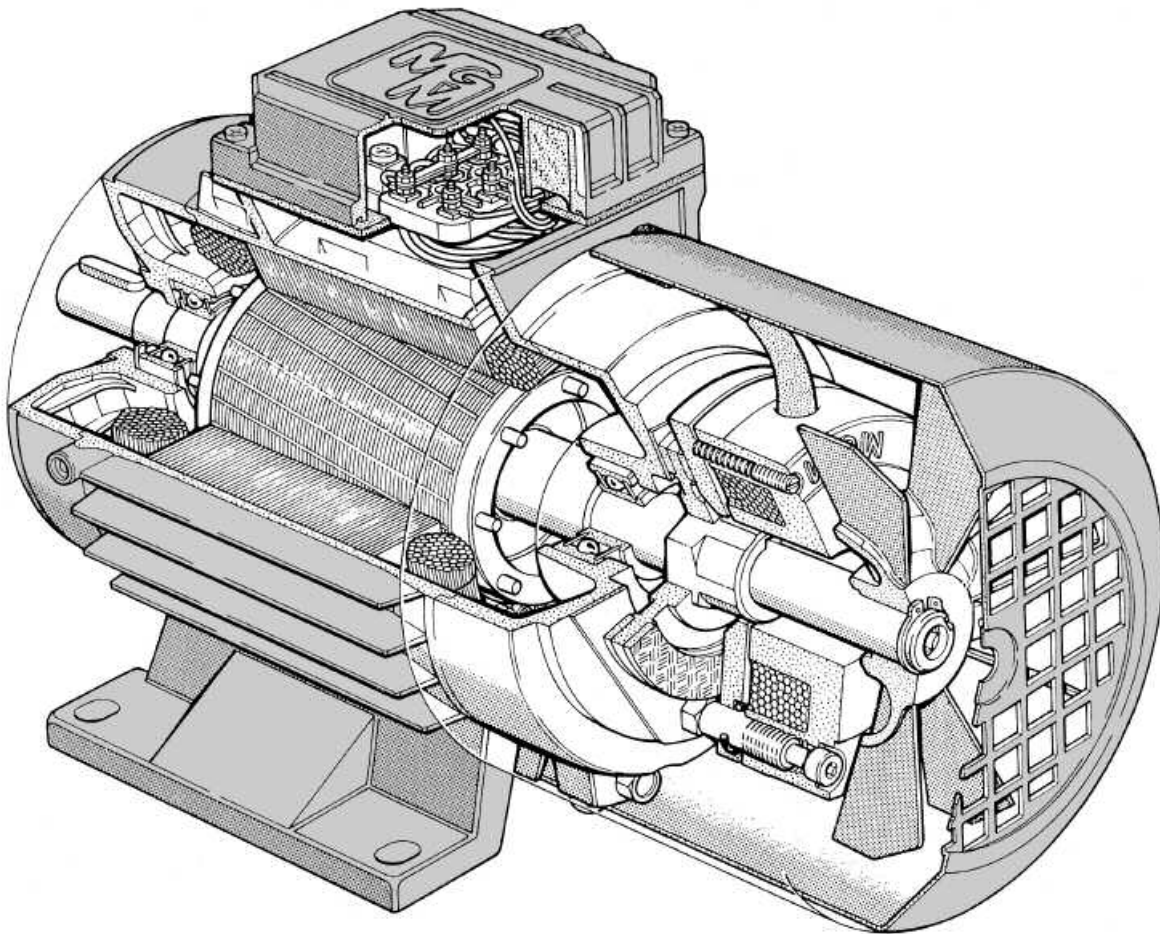

# BM series brake group

## General description

BM series motors are equipped with DC brake coil. DC brake coil is supplied through a rectifier located in the terminal box (standard voltage supply is 230V 50/60 Hz). The rectifier is provided with over-voltage protection devices. The brake torque remains the same in both directions of rotation and the motor brakes without shaft axial sliding. Brake torque can be set loosening or tightening the adjustable springs (78) where available or in the presence of fixed springs, removing the central springs or replacing the springs with ones of another type.

Never set the brake torque to a higher value than the one indicated on the motor nameplate. BM series motors are fitted as standard with a hexagonal hole on the shaft at non drive end to allow manual rotation. On request BM series motors can be provided with brake release return lever located on the motor side.

## Air gap adjustment

The air gap (60), that is the distance between the two magnetic cores, the brake coil (75) and brake moving element (74), must stay within the value expressed in the chart below. It is advisable to check periodically the air gap because it increases as a consequence of the brake disc wear. In order to restore the air gap within the proper value, release the connecting screws (77), move the brake coil (75) towards the brake moving element (74) operating on the fixing screws (79). Once this operation has been settled be sure to tighten clockwise the connecting screws (77) so to fasten again the brake coil.

Frame Size	63/71	80	90	100	112	132	160	180	200	225
Min Air Gap [mm]	0.2	0.2	0.3	0.3	0.3	0.4	0.4	0.5	0.5	0.5
Max Air Gap [mm]	0.6	0.6	0.7	0.7	0.8	0.8	0.9	1.0	1.0	1.0

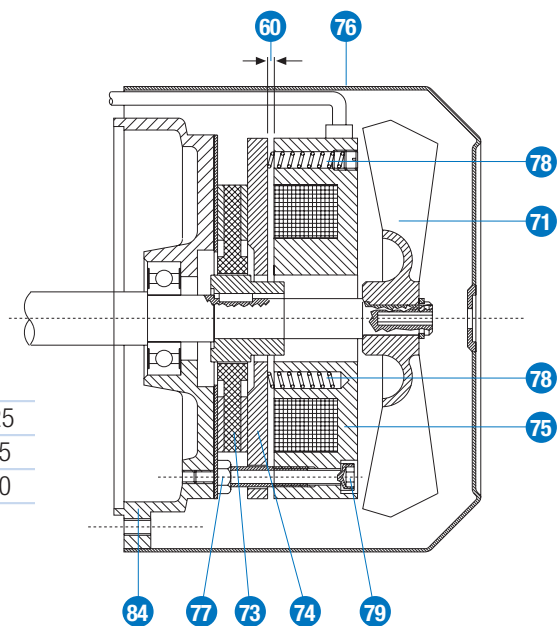

## Permissible start frequency with load

The technical data tables provide the ideal no-load start frequency ( $Z_0$ ). The permissible start frequency when an external load is applied ( $Z_{load}$ ) can be calculated as follows:

$$Z_{load} = Z_0 \cdot K \cdot R$$

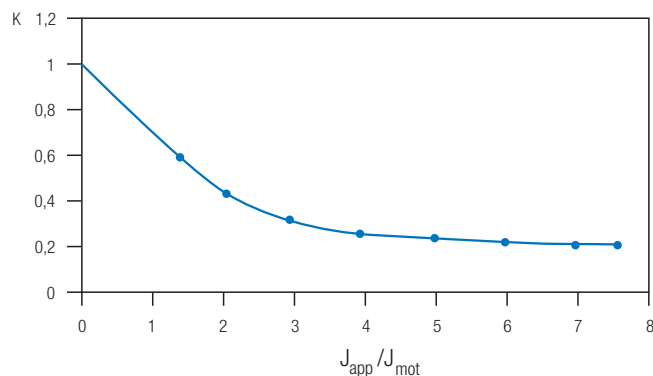
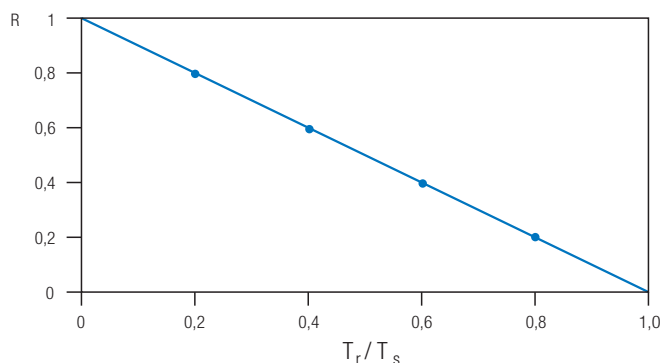

where “ $Z_0$ ” is the table-value for the selected motor and “ $K$ ” and “ $R$ ” are factors determined by the curves shown above; the factor “ $K$ ” refers to the calculated ratio between the moment of inertia of the applied load ( $J_{app}$ ) and that of the motor ( $J_{mot}$ ) while the factor “ $R$ ” is the calculated ratio between the resisting torque ( $T_r$ ) and the starting torque ( $T_s$ ). This calculation gives an approximative indication and it has to be operatively tested for confirmation. If the required starting frequency is close to  $Z_{load}$ , it is advisable to use a motor equipped with thermal protectors. It is necessary to check the maximum energy dissipation limit of the brake group and the maximum motor RPM on those application where high moment of inertia is involved. Please contact MGM technical staff for additional information.

## Rectifiers wiring diagram

BM series brake motors can be connected as diagram A or B according to the required braking time. MGM motors are always provided with the DC brake coil connected as diagram A. The DC brake coil has to be connected according to diagram B in order to have a quicker braking action. Here below brake intervention times and brake release times are provided.

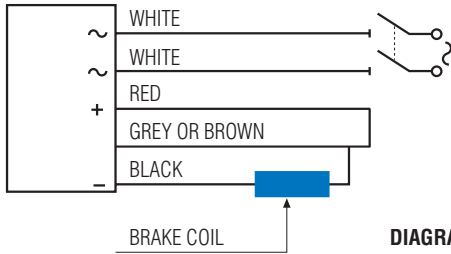

DIAGRAM A

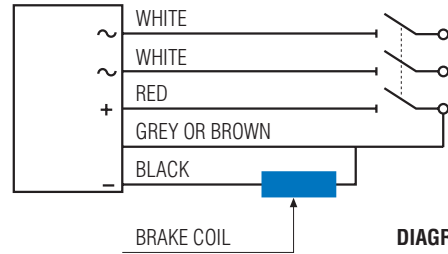
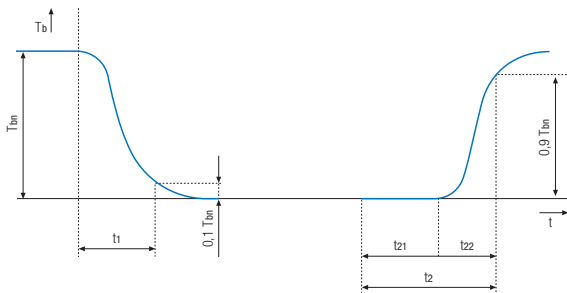

DIAGRAM B

The chart here below describes the trend of the braking torque as a function of time, during the start (on the left) and stop (on the right). The table below also show times for each type of motor and the values of  $E_r$  (MJ) to calculate the number of braking actions between two consecutive air gap adjustments. Values shown in the table must be considered as indicative only, as they can be influenced by various factors (air gap, voltages, temperature, rectifier type, etc.). The values shown in the table are referred to the case when the brake supply line is separated from that of the motor.



- $T_b$  Brake torque
- $T_{bn}$  Nominal brake torque
- $t_1$  Switch-on time
- $t_{21}$  Delay time
- $t_{22}$  Rise time
- $t_2$  Brake electrical reaction time

Frame size	$t_1$ (ms)	$t_{21}$ quick (ms)	$t_{22}$ quick (ms)	$t_2$ quick (ms)	$t_{21}$ standard (ms)	$t_{22}$ standard (ms)	$t_2$ standard (ms)	$E_r$ (MJ)
56	30	10	15	25	35	25	60	7*
63	35	20	15	35	60	30	90	15
71	35	20	15	35	60	30	90	15
80	45	20	30	50	100	45	145	23
90	60	20	40	60	120	60	180	29
100	80	25	50	75	150	75	225	36
112	120	30	60	90	200	90	290	45
132	160	40	80	120	300	120	420	60
160	250	50	100	150	320	250	570	70
180	300	60	120	180	400	200	600	110
200	300	60	120	180	400	200	600	110
225	400	70	120	200	550	350	900	190

\* Note: the air gap can't be restored on BM56 motors. The brake disc has to be replaced when the air gap exceed the stated value.

## Braking time

The braking time  $t_r$  (s) can be calculated as follows:  $t_r = \frac{J_{tot} \cdot n}{9.55 (T_b \pm T_{load})} + \frac{t_2}{1000}$

- where:  $J_{tot}$  total moment of inertia at the motor shaft (Kgm<sup>2</sup>)
- $n$  motor RPM (min<sup>-1</sup>)
- $T_b$  brake torque (Nm)
- $T_{load}$  resisting load torque (Nm) with + sign if matches the brake torque, or - sign if opposite
- $t_2$  brake electrical reaction time (ms)

### IE1 - 50 Hz

Motor type	Power (kW)	RPM	In (A) 400 V	cos φ	Eff.	Tn (Nm)	Ts / Tn	Is / In	DC brake In (mA)	Z <sub>0</sub> (starts /hour)	Moment of inertia Jx 10 <sup>-4</sup> Kg·m <sup>2</sup>	Max Brake torque (Nm)	A-Sound pressure dB (A)	Weight (Kg)
<b>2 pole - 3000 RPM</b>														
BM 56 A2	0.09	2820	0.38	0.60	59.3	0.30	3.0	3.8	130	10000	1.85	2	58	4.0
BM 56 B2	0.12	2760	0.40	0.69	53.5	0.42	3.0	3.8	130	10000	1.85	2	58	4.0
BM 63 A2	0.18	2800	0.60	0.71	60.3	0.61	3.0	3.5	200	9000	1.93	5	59	4.5
BM 63 B2	0.25	2800	0.75	0.76	64.7	0.85	3.5	5.0	200	7500	1.93	5	59	5.0
BM 63 C2*	0.37	2760	1.00	0.80	69.0	1.26	2.5	3.8	200	6000	2.30	5	59	5.5
BM 71 A2	0.37	2810	0.90	0.78	69.4	1.26	2.6	4.5	200	4150	3.35	5	59	7
BM 71 B2	0.55	2810	1.40	0.78	72.0	1.87	2.6	4.5	200	4150	3.95	5	59	8
BM 71 C2*	0.75	2810	1.80	0.80	73.2	2.55	2.5	4.5	200	3100	4.62	5	59	9
BM 80 A2	0.75	2800	1.70	0.86	74.0	2.56	3.1	5.3	160	3100	7.29	10	65	12
BM 80 B2	1.1	2800	2.40	0.86	76.5	3.75	3.1	5.3	160	3100	8.61	10	65	13
BM 90 SA2	1.5	2850	3.20	0.86	77.2	5.03	3.0	6.9	190	2550	14.54	20	72	17
BM 90 LA2	2.2	2840	4.50	0.86	79.7	7.40	3.0	6.9	190	2550	17.43	20	72	19
BM 100 LA2	3.0	2860	6.20	0.84	81.5	10.02	3.2	8.1	250	1850	33.18	40	74	23
BM 112 MB2	4.0	2880	8.10	0.84	83.1	13.26	2.5	7.4	470	1100	67.89	60	75	38
BM 112 MC2*	5.5	2880	11.40	0.85	84.7	18.24	2.5	7.4	470	900	83.70	60	75	40
BM 132 SA2	5.5	2890	10.8	0.86	84.7	18.17	2.8	7.4	600	350	150.90	100	75	59
BM 132 SB2	7.5	2890	14.6	0.85	86.9	24.78	2.8	7.4	600	350	189.90	100	75	65
BM 132 MA2*	9.2	2890	17.9	0.85	86.9	30.40	2.8	7.4	600	300	229.70	100	75	71
BM 132 MB2*	11.0	2890	21.4	0.85	85.7	36.35	2.8	7.4	600	300	267.70	100	75	78
BM 160 MA2	11.0	2920	19.5	0.94	88.0	35.98	3.0	8.8	700	250	461.00	150	77	142
BM 160 MB2	15.0	2930	26.3	0.93	89.2	48.89	3.1	8.8	700	250	461.00	150	77	142
BM 160 LA2	18.5	2930	32.4	0.93	89.4	60.30	3.1	8.8	700	250	540.00	150	77	153
BM 180 LA2	22.0	2950	36.7	0.95	89.9	71.22	2.7	9.0	700	100	1010.00	250	78	230
BM 200 LA2	30.0	2940	52.0	0.94	89.4	97.45	2.8	9.0	700	80	1100.00	250	79	260
BM 200 LB2	37.0	2940	64.1	0.93	89.9	120.19	2.8	9.0	700	80	1150.00	250	79	270
<b>4 pole - 1500 RPM</b>														
BM 56 A4	0.06	1390	0.40	0.48	45.0	0.41	3.0	2.2	130	12000	1.85	2	41	4.0
BM 56 B4*	0.09	1320	0.41	0.61	55.0	0.65	3.0	2.2	130	12000	1.85	2	41	4.0
BM 56 C4	0.12	1320	0.55	0.61	54.0	0.87	3.0	2.2	130	12000	1.85	2	41	4.0
BM 63 A4	0.12	1330	0.45	0.70	55.0	0.86	2.0	2.4	200	12000	2.47	5	42	4.5
BM 63 B4	0.18	1350	0.60	0.71	61.0	1.27	3.0	2.8	200	12000	3.08	5	42	5.0
BM 63 C4*	0.22	1350	0.75	0.66	63.0	1.56	2.8	3.1	200	12000	3.55	5	42	5.5
BM 63 D4*	0.30	1350	1.05	0.64	55.5	2.12	2.8	3.0	200	12000	3.83	5	42	6.0
BM 71 A4	0.25	1400	0.80	0.65	63.0	1.71	2.5	3.7	200	10300	5.67	5	45	7.0
BM 71 B4	0.37	1400	1.10	0.68	67.0	2.52	2.7	3.9	200	10300	6.57	5	45	8.0
BM 71 C4*	0.55	1360	1.65	0.70	70.0	3.86	2.4	3.7	200	8150	7.90	5	45	9.0
BM 71 D4*	0.65	1350	2.00	0.69	71.7	4.60	2.1	3.7	200	8150	8.39	5	45	9.5
BM 80 A4	0.55	1400	1.70	0.69	70.0	3.75	2.1	4.0	160	8150	10.62	10	47	12.0
BM 80 B4	0.75	1400	2.20	0.67	73.5	5.12	2.5	4.3	160	7250	13.50	10	47	13.0
BM 80 C4*	0.90	1390	2.60	0.68	73.6	6.18	2.8	4.5	160	5150	13.95	10	47	14.0
BM 90 SA4	1.10	1400	2.70	0.77	77.4	7.50	2.3	4.6	190	5150	21.74	20	55	16.5
BM 90 LA4	1.50	1400	3.60	0.75	78.3	10.23	2.7	4.8	190	4100	26.12	20	55	19.0
BM 90 LB4*	1.85	1400	4.30	0.77	78.7	12.62	2.7	5.8	190	4100	30.16	20	55	21.5
BM 90 LC4*	2.2	1390	5.40	0.75	77.3	15.12	2.7	5.0	190	4100	30.16	20	55	21.5
BM 100 LA4	2.2	1410	5.00	0.78	80.8	14.90	2.5	5.4	250	3300	44.50	40	57	25
BM 100 LB4	3.0	1410	6.50	0.80	83.1	20.32	2.8	6.4	250	3300	53.43	40	57	29
BM 112 MB4	4.0	1415	8.10	0.84	83.7	27.00	2.6	6.4	470	1600	111.50	60	61	39
BM 112 MC4*	5.5	1420	11.50	0.83	84.7	36.99	2.8	6.9	470	1100	155.00	60	61	44
BM 132 SB4	5.5	1430	11.30	0.82	85.2	36.73	2.4	6.0	600	500	235.90	100	62	66
BM 132 MA4	7.5	1435	14.80	0.84	86.4	49.91	2.4	6.0	600	400	310.90	100	62	75
BM 132 MB4*	9.2	1445	18.30	0.85	87.3	60.80	2.5	6.3	600	400	391.30	100	62	88
BM 132 MC4*	11.0	1440	21.70	0.86	87.6	72.95	2.5	6.0	600	400	391.30	100	62	88
BM 160 MA4	9.2	1460	18.60	0.84	87.2	60.18	3.0	7.0	700	370	531.00	150	63	130
BM 160 MB4	11.0	1460	21.20	0.85	88.0	71.95	2.9	7.0	700	370	607.00	150	63	136
BM 160 LA4	15.0	1460	28.50	0.87	89.7	98.12	2.7	7.0	700	370	782.00	150	63	153
BM 180 LA4	18.5	1460	33.7	0.89	90.6	121.01	2.9	8.0	700	340	1600.00	250	64	230
BM 180 LB4	22.0	1460	41.8	0.85	90.0	143.90	2.5	7.6	700	340	1600.00	250	64	230
BM 200 LB4	30.0	1455	56.5	0.87	90.7	196.91	2.5	7.4	700	250	1840.00	250	66	260
BM 225 S4	37.0	1475	68.1	0.85	92.7	239.56	2.5	7.9	920	240	4130.00	400	68	370
BM 225 M4	45.0	1475	82.6	0.85	93.1	291.36	2.5	7.9	920	230	4800.00	400	68	405

### IE1 - 50 Hz

Motor type	Power (kW)	RPM	In (A) 400 V	cos φ	Eff.	Tn (Nm)	Ts / Tn	Is / In	DC brake In (mA)	Z <sub>0</sub> (starts /hour)	Moment of inertia Jx 10 <sup>-4</sup> Kg·m <sup>2</sup>	Max Brake torque (Nm)	A-Sound pressure dB (A)	Weight (Kg)
6 pole - 1000 RPM														
BM 56 B6	0.06	850	0.45	0.71	25.6	0.67	1.9	0.5	130	12000	1.85	2	41	4.0
BM 63 C6	0.09	890	0.50	0.56	42.7	0.97	2.4	1.9	200	12000	3.55	5	42	5.5
BM 63 D6	0.12	870	0.60	0.60	45.0	1.32	2.7	1.9	200	12000	3.83	5	42	6.0
BM 71 A6	0.18	875	0.60	0.71	56.0	1.96	2.0	2.6	200	11500	8.55	5	45	7.5
BM 71 B6	0.25	900	0.80	0.71	59.0	2.65	2.0	2.8	200	11500	10.01	5	45	8.0
BM 80 A6	0.37	910	1.25	0.67	64.0	3.88	2.6	3.4	160	9700	19.05	10	47	12.0
BM 80 B6	0.55	900	1.80	0.68	65.8	5.84	2.2	2.8	160	9250	22.86	10	47	13.0
BM 90 SA6	0.75	910	2.30	0.68	70.1	7.87	2.1	3.5	190	7300	31.52	20	54	16.0
BM 90 LA6	1.10	910	3.20	0.68	72.9	11.54	2.2	3.6	190	5400	41.67	20	54	18.5
BM 90 LB6*	1.30	910	3.90	0.68	74.2	13.64	2.5	4.0	190	4300	48.10	20	54	20.5
BM 100 LA6	1.50	930	3.90	0.71	78.6	15.40	2.3	4.3	250	3650	80.76	40	56	26
BM 100 LB6	1.85	920	5.00	0.68	76.6	19.20	2.6	4.5	250	3200	92.55	40	56	28
BM 112 MB6	2.20	945	5.20	0.79	78.2	22.23	2.0	5.3	470	2100	163.50	60	58	39
BM 132 SB6	3.00	960	7.20	0.72	83.0	29.84	2.5	6.5	600	650	304.90	100	58	66
BM 132 MA6	4.00	960	9.50	0.72	83.9	39.79	2.3	6.5	600	550	360.70	100	58	71
BM 132 MB6	5.50	960	12.30	0.75	84.3	54.71	2.3	6.5	600	550	467.70	100	58	82
BM 160 MB6	7.50	965	15.90	0.79	85.3	74.22	2.2	7.1	700	550	867.00	150	59	138
BM 160 LA6*	9.20	970	18.30	0.81	87.0	90.58	2.2	7.1	700	500	1160.00	150	59	156
BM 160 LB6	11.00	970	22.70	0.80	88.0	108.30	2.5	7.5	700	440	1160.00	150	59	156
BM 180 LB6	15.00	970	29.40	0.84	89.0	147.68	2.3	7.8	700	420	1930.70	250	60	230
BM 200 LA6	18.50	970	38.10	0.82	88.6	182.14	2.2	8.0	700	350	2220.00	250	61	260
BM 200 LB6	22.00	965	43.50	0.85	89.2	217.72	2.2	8.0	700	350	2220.00	250	61	260
BM 225 M6**	30.00	980	60.70	0.78	91.7	219.47	2.2	8.0	920	300	7130.00	400	63	405
8 pole - 750 RPM														
BM 63 D8	0.07	650	0.45	0.62	28.0	1.03	2.2	1.55	200	15000	3.83	5	42	6.0
BM 71 A8	0.08	660	0.60	0.53	42.9	1.16	2.0	2.0	200	8750	5.67	5	43	7.5
BM 71 B8	0.11	660	0.80	0.55	43.7	1.59	2.0	2.0	200	8750	6.57	5	43	8.0
BM 80 A8	0.18	675	0.95	0.59	50.3	2.55	2.0	2.2	160	8150	19.05	10	45	12.0
BM 80 B8	0.25	675	1.25	0.62	52.1	3.54	2.0	2.2	160	7250	22.86	10	45	13.0
BM 90 SA8	0.37	690	1.50	0.60	60.6	5.12	2.1	2.9	190	7000	31.52	20	46	16.5
BM 90 LA8	0.55	690	2.20	0.56	61.4	7.61	2.1	2.8	190	5400	41.67	20	46	19
BM 90 LB8*	0.65	690	2.70	0.56	64.9	9.00	2.1	2.8	190	4400	48.00	20	46	21
BM 100 LA8	0.75	700	2.75	0.58	68.1	10.23	2.1	3.0	250	3850	80.76	40	49	26
BM 100 LB8	1.1	700	4.10	0.59	70.2	15.01	2.5	4.0	250	3600	92.55	40	49	28
BM 112 MB8	1.5	705	4.90	0.60	73.6	20.32	2.0	4.5	470	2500	163.50	60	52	39
BM 132 SB8	2.2	700	5.20	0.75	80.8	30.01	2.1	4.7	600	700	283.90	100	55	61
BM 132 MB8	3.0	700	7.10	0.75	80.8	40.93	2.1	4.7	600	700	372.70	100	55	68
BM 160 MA8	4.0	725	9.60	0.72	83.1	52.69	2.3	6.5	700	630	959.00	150	58	138
BM 160 MB8	5.5	725	13.60	0.70	83.5	72.45	2.3	6.1	700	630	959.00	150	58	138
BM 160 LA8	7.5	725	18.60	0.70	83.8	98.79	2.3	6.1	700	630	1280.00	150	58	156
BM 180 LB8	11.0	730	25.90	0.72	85.8	143.90	2.0	5.9	700	600	2320.00	250	59	230
BM 200 LA8	15.0	730	32.80	0.77	87.3	196.23	1.9	6.1	700	400	2740.00	250	60	260
BM 225 M8**	22.0	735	51.30	0.71	90.5	285.85	2.1	6.4	920	300	7130.00	400	62	405

1. Motor characteristic values reported in the tables refer to continuous duty (S1), 50 Hz frequency, ambient temperature max. 40 °C, altitude up to 1000 m. above sea level operating condition.  
 2. The expressed brake torque is the max admissible one. Brake current consumption values refer to a rated voltage of 230V AC single-phase.  
 3. The table shows the sound pressure noise level, measured at one metre range from the motor according to the Acurve (ISO 1680). The shown noise levels refer to motor no-load operating condition and should be regarded with a tolerance of ± 3dB.  
 4. The brake torque indicated on the chart is the maximum one that can be reached.

5. Z<sub>0</sub> is the max number of no-load starts. It is meant for calculation purposes only, and is used to obtain the max number of starts with load according to the formula expressed at page 42. The number of starts with load (Z<sub>load</sub>) is indicative and it has to be operatively tested for confirmation. The use of thermal protectors is strongly recommended when the operative number of starts is close to the calculated Z<sub>load</sub>. It is necessary to verify the max permissible brake energy dissipation and the max permissible RPM for applications with high moment of inertia.  
 6. Efficiency data at 50% and 75% of the full load are available in the specific product documentation.

7. The international standard IEC 60034-30-1 doesn't specify efficiency classes for motors with rated power less than 0,12 kW.  
 8. The \*\* beside the motor type identifies non-standard motor powers for their frame size. Such motors might not meet the IE1 efficiency class. The \*\*\* beside the motor type identifies those motors that meet the IE2 efficiency class.  
 9. MGM keeps the data provided as up-to-date and correct as possible. Since the products are subject to changes and improvements, the data indicated cannot be considered binding. The data indicated must also be understood as being general in nature. For specific applications, please contact the MGM staff.

# technical data two speed motors - single winding

Motor type	Power (kW)	RPM	In (A) 400 V	cos φ	Tn (Nm)	Ts / Tn	Is / In	DC brake In (mA)	Z <sub>0</sub> (starts /hour)	Moment of inertia Jx 10 <sup>-4</sup> Kg·m <sup>2</sup>	Max Brake torque (Nm)	A-Sound pressure dB (A)	Weight (Kg)
2/4 pole													3000 / 1500 r.p.m.
BMD 63 B2/4	0.22 0.15	2800 1400	0.80 0.75	0.68 0.56	0.75 1.02	3.00 3.00	4.5 3.2	200	5500 7000	3.08	5	55 42	5.0
BMD 63 C2/4	0.26 0.17	2800 1400	0.90 0.85	0.76 0.61	0.89 1.16	2.90 3.00	4.2 3.3	200	5000 6000	3.55	5	55 42	5.5
BMD 71 A2/4	0.25 0.18	2820 1415	0.75 0.70	0.73 0.66	0.85 1.21	2.2 2.4	3.8 3.1	200	2850 5500	5.67	5	59 45	7.0
BMD 71 B2/4	0.37 0.25	2820 1415	1.00 0.85	0.77 0.63	1.25 1.69	2.3 2.8	4.7 4.2	200	2850 5500	6.47	5	59 45	8.0
BMD 80 A2/4	0.65 0.45	2790 1400	1.80 1.35	0.81 0.72	2.22 3.07	2.0 2.1	4.1 4.0	160	2500 4400	10.62	10	65 47	12.0
BMD 80 B2/4	0.88 0.62	2800 1390	2.20 1.70	0.80 0.74	3.00 4.26	2.5 2.2	4.9 4.5	160	2500 4400	12.84	10	65 47	13.0
BMD 90 SB2/4	1.3 0.9	2800 1420	3.20 2.30	0.85 0.73	4.43 6.05	2.3 2.5	5.2 5.0	190	1650 2900	21.74	20	72 55	16.5
BMD 90 LA2/4	1.8 1.2	2800 1420	4.40 3.10	0.83 0.71	6.14 8.07	2.6 3.0	5.6 6.0	190	1200 2100	26.12	20	72 55	19.5
BMD 90 LB2/4	2.2 1.5	2860 1430	5.40 3.80	0.82 0.73	7.35 10.02	2.5 3.0	5.9 6.0	190	1050 1750	30.16	20	72 55	20.5
BMD 100 LA2/4	2.2 1.5	2875 1425	5.00 3.80	0.85 0.81	7.31 10.05	2.3 2.5	6.0 5.6	250	1050 1750	44.5	40	74 57	25
BMD 100 LB2/4	3.1 2.3	2875 1425	6.70 5.20	0.85 0.82	10.30 15.41	2.3 2.4	7.0 6.5	250	850 1400	53.4	40	74 57	29
BMD 112 MB2/4	4.5 3.3	2880 1400	9.20 6.90	0.88 0.86	14.92 22.51	2.4 2.6	7.0 6.5	470	350 1400	133.5	60	75 61	39
BMD 132 SB2/4	5.0 4.5	2940 1450	10.90 9.30	0.81 0.84	16.24 29.64	2.8 2.6	8.0 7.5	600	150 350	235.9	100	75 62	66
BMD 132 MA2/4	6.0 5.0	2940 1450	11.70 10.00	0.88 0.85	19.49 32.93	2.1 2.5	8.0 7.5	600	150 320	310.9	100	75 62	75
BMD 132 MB2/4	7.5 6.0	2940 1450	16.00 12.20	0.82 0.83	24.36 39.52	2.4 2.5	8.0 7.5	600	150 320	310.9	100	75 62	75
BMD 160 MA2/4	9.5 8.0	2870 1420	20.00 16.60	0.89 0.85	31.61 53.80	2.8 2.6	7.5 6.0	700	120 320	607.0	150	77 63	136
BMD 160 MB2/4	11.0 9.0	2870 1420	23.30 18.70	0.88 0.85	36.60 60.53	2.8 2.6	6.8 6.0	700	120 320	607.0	150	77 63	136
BMD 160 LA2/4	13.0 11.0	2890 1420	26.10 21.20	0.91 0.87	42.96 73.98	2.8 2.6	7.0 6.3	700	100 300	782.0	150	77 63	153
4/8 pole													1500 / 750 r.p.m.
BMD 71 A4/8	0.13 0.07	1385 700	0.35 0.45	0.82 0.60	0.90 0.96	1.6 1.8	3.0 2.0	200	4300 7300	8.55	5	45 43	8.0
BMD 71 B4/8	0.18 0.09	1370 685	0.50 0.60	0.83 0.59	1.25 1.25	1.8 2.0	3.2 2.0	200	4100 6900	10.01	5	45 43	8.5
BMD 71 C4/8	0.22 0.12	1370 685	0.60 0.75	0.83 0.59	1.53 1.67	1.6 1.8	3.0 2.0	200	3850 6700	10.82	5	45 43	9.0
BMD 80 A4/8	0.25 0.18	1405 675	0.70 0.90	0.86 0.65	1.70 2.55	2.2 2.0	4.1 2.4	160	4300 7300	19.05	10	47 45	12.0
BMD 80 B4/8	0.37 0.25	1405 675	0.85 1.15	0.86 0.65	2.51 3.54	2.2 2.0	4.1 2.4	160	3250 5500	22.86	10	47 45	13.0
BMD 90 SA4/8	0.75 0.37	1350 695	1.70 1.80	0.85 0.53	5.31 5.08	1.8 2.3	3.9 2.7	190	3200 5500	31.52	20	55 46	16.5
BMD 90 LB4/8	1.1 0.6	1390 695	2.70 3.00	0.82 0.53	7.56 8.24	2.0 2.5	4.5 2.7	190	2900 4900	48.21	20	55 46	20.5
BMD 100 LB4/8	1.6 0.9	1395 700	3.60 3.50	0.87 0.58	10.95 12.28	2.0 2.2	5.0 3.5	250	1850 3100	92.55	40	57 49	28
BMD 112 MB4/8	2.2 1.2	1440 720	4.80 4.60	0.86 0.57	14.59 15.92	2.5 3.1	5.5 4.1	470	1400 3000	200.60	60	61 52	39
BMD 132 SB4/8	3.0 2.0	1440 720	6.60 5.80	0.85 0.64	19.90 26.53	2.2 2.5	6.0 5.0	600	380 750	283.90	100	62 55	61
BMD 132 MA4/8	4.0 2.7	1440 720	8.80 7.80	0.85 0.64	26.53 35.81	2.2 2.5	6.0 5.0	600	380 750	372.70	100	62 55	68
BMD 132 MB4/8	6.0 4.0	1440 720	13.00 11.60	0.85 0.64	39.79 53.06	2.2 2.5	6.0 5.0	600	380 750	533.70	100	62 55	106
BMD 160 MB4/8	6.5 4.5	1470 730	15.10 13.30	0.80 0.62	42.23 58.87	2.6 2.5	2.4 5.0	700	320 580	959.00	150	63 58	138
BMD 160 LA4/8	9.5 6.0	1470 730	21.50 17.60	0.82 0.62	61.72 78.49	2.6 2.4	8.0 6.5	700	300 560	1280.00	150	63 58	156

# technical data two speed motors - two windings



BM series

Motor type	Power (kW)	RPM	In (A) 400 V	cos φ	Tn (Nm)	Ts / Tn	Is / In	DC brake In (mA)	Z <sub>0</sub> (starts /hour)	Moment of inertia Jx 10 <sup>-4</sup> Kg·m <sup>2</sup>	Max Brake torque (Nm)	A-Sound pressure dB (A)	Weight (Kg)
2/6 pole												3000 / 1000 r.p.m.	
BMDA 71 B2/6	0.25 0.08	2880 940	0.85 0.60	0.74 0.64	0.83 0.81	2.6 2.2	4.3 2.0	200	7300 14400	6.57	5	59 45	8.5
BMDA 71 C2/6	0.35 0.10	2880 940	1.05 0.60	0.75 0.59	1.16 1.02	2.6 2.2	5.0 2.3	200	6850 13500	7.90	5	59 45	9.5
BMDA 80 A2/6	0.37 0.12	2885 945	1.35 0.80	0.67 0.57	1.22 1.21	2.6 1.9	5.0 2.5	160	4150 11000	10.62	10	65 47	12.0
BMDA 80 B2/6	0.55 0.18	2885 945	1.75 1.05	0.67 0.57	1.82 1.82	2.6 1.9	5.0 2.5	160	3100 9200	12.84	10	65 47	13.0
BMDA 90 SA2/6	0.9 0.3	2875 950	2.10 1.15	0.86 0.65	2.99 3.02	2.5 2.2	5.0 2.5	190	2300 6850	21.74	20	72 54	16.5
BMDA 90 LA2/6	1.2 0.4	2875 950	2.80 1.55	0.86 0.65	3.99 4.02	2.5 2.2	5.0 2.5	190	2000 5450	26.12	20	72 54	19.5
BMDA 90 LB2/6	1.4 0.5	2890 940	3.20 1.80	0.86 0.55	4.63 5.08	2.7 2.5	5.0 3.0	190	1650 4100	30.16	20	72 54	20.5
BMDA 100 LA2/6	1.6 0.6	2810 900	3.70 1.90	0.85 0.68	5.44 6.37	2.6 2.3	5.4 3.4	250	1650 4100	44.50	40	74 56	25
BMDA 100 LB2/6	2.2 0.8	2800 910	4.80 2.50	0.90 0.67	7.50 8.40	2.6 2.3	5.4 3.4	250	1550 3650	53.43	40	74 56	28
BMDA 112 MB2/6	3.0 1.0	2870 950	6.40 3.20	0.86 0.61	9.98 10.05	3.0 3.2	7.0 4.5	470	450 3250	133.50	60	75 58	26
BMDA 132 SB2/6	4.0 1.3	2880 940	8.90 3.70	0.85 0.69	13.26 13.21	3.0 2.8	7.0 4.5	600	150 650	235.90	100	75 58	66
BMDA 132 MA2/6	5.5 1.8	2870 940	11.50 5.10	0.88 0.69	18.30 18.29	3.0 2.8	7.5 4.5	600	150 550	310.90	100	75 58	75
BMDA 132 MB2/6	7.0 2.2	2870 940	14.90 6.30	0.88 0.69	23.29 22.35	3.0 2.8	7.5 4.5	600	150 450	391.30	100	75 58	76
BMDA 160 MB2/6	8.0 2.5	2890 950	15.90 6.90	0.92 0.74	26.44 25.13	3.0 2.0	8.0 4.3	700	100 400	607.00	150	77 59	136
BMDA 160 LA2/6	11.0 3.6	2890 950	21.40 9.30	0.92 0.74	36.35 36.19	3.0 2.0	8.0 4.3	700	100 360	782.00	150	77 59	153
2/8 pole												3000 / 750 r.p.m.	
BMDA 63 C2/8	0.18 0.04	2850 635	0.60 0.45	0.78 0.70	0.60 0.60	2.2 1.9	5.0 2.1	200	2500 1800	3.55	5	55 42	5.5
BMDA 71 B2/8	0.25 0.06	2900 700	0.85 0.55	0.69 0.54	0.82 0.82	2.5 1.8	4.0 1.5	200	7300 17500	6.57	5	59 43	8.5
BMDA 71 C2/8	0.35 0.07	2900 700	1.05 0.75	0.70 0.52	1.15 0.96	2.5 2.2	4.3 1.6	200	6150 14400	7.90	5	59 43	9.5
BMDA 80 A2/8	0.37 0.09	2885 690	1.35 0.70	0.67 0.54	1.22 1.25	2.3 1.8	5.0 1.7	160	4100 13500	10.62	10	65 45	12.0
BMDA 80 B2/8	0.55 0.12	2885 690	1.75 0.90	0.67 0.54	1.82 1.66	2.3 2.0	5.0 1.7	160	3100 12750	12.84	10	65 45	13.0
BMDA 90 SB2/8	0.75 0.18	2800 610	1.90 1.05	0.77 0.65	2.56 2.82	3.0 2.1	5.1 1.9	190	1950 9250	21.74	20	72 46	16.5
BMDA 90 LA2/8	1.10 0.25	2800 640	2.70 1.45	0.80 0.64	3.75 3.73	3.0 2.1	5.1 1.9	190	1750 7750	26.12	20	72 46	19.5
BMDA 90 LB2/8	1.3 0.3	2820 640	3.10 1.75	0.81 0.58	4.40 4.48	3.2 2.4	5.7 2.0	190	1650 7250	30.16	20	72 46	20.5
BMDA 100 LA2/8	1.6 0.4	2810 660	3.70 2.00	0.85 0.58	5.44 5.79	2.7 2.0	5.3 2.2	250	1650 5750	44.50	40	73 49	25
BMDA 100 LB2/8	2.2 0.5	2800 660	4.80 2.50	0.90 0.59	7.50 7.23	2.8 2.3	5.7 2.3	250	1550 5100	53.43	40	73 49	29
BMDA 112 MB2/8	3.0 0.8	2860 690	6.30 3.50	0.87 0.63	10.02 11.07	3.3 2.6	7.5 3.2	470	650 4200	133.50	60	75 61	39
BMDA 132 SB2/8	4.0 1.1	2880 680	8.90 4.00	0.85 0.60	13.26 15.45	3.0 1.9	7.0 3.3	600	260 1100	235.90	100	75 62	66
BMDA 132 MA2/8	5.5 1.5	2870 680	11.50 5.60	0.88 0.59	18.30 21.07	3.0 2.0	7.5 3.0	600	250 1100	310.90	100	75 62	75
BMDA 132MB2/8	7.0 1.8	2870 680	14.90 7.30	0.88 0.59	23.29 25.28	3.0 2.0	7.5 3.0	600	250 1100	391.30	100	75 62	86
BMDA 160 MB2/8	8.0 2.2	2880 705	16.70 7.60	0.91 0.65	26.53 29.80	3.0 1.9	8.0 3.3	700	180 900	607.00	150	77 58	136
BMDA 160 LA2/8	11.0 3.0	2880 710	21.50 10.20	0.92 0.95	36.48 40.35	3.0 1.9	8.0 3.3	700	180 900	782.00	150	77 58	153

1. Motor characteristic values reported in the tables refer to continuous duty (S1), 50 Hz frequency, ambient temperature max. 40 °C, altitude up to 1000 m. above sea level operating condition.  
 2. The expressed brake torque is the max admissible one. Brake current consumption values refer to a rated voltage of 230V AC single-phase.  
 3. The table shows the sound pressure noise level, measured at one metre range from the motor according to the Acurve (ISO 1680). The shown noise levels refer to motor no-load operating condition and should

be regarded with a tolerance of ± 3dB.  
 4. The brake torque indicated on the chart is the maximum one that can be reached.  
 5. Z<sub>0</sub> is the max number of no-load starts. It is meant for calculation purposes only, and is used to obtain the max number of starts with load according to the formula expressed at page 42. The number of starts with load (Z<sub>load</sub>) is indicative and it has to be operatively tested for confirmation. The use of thermal protectors is strongly recommended when the oper-

ative number of starts is close to the calculated Z<sub>load</sub>. It is necessary to verify the max permissible brake energy dissipation and the max permissible RPM for applications with high moment of inertia.  
 6. MGM keeps the data provided as up-to-date and correct as possible. Since the products are subject to changes and improvements, the data indicated cannot be considered binding. The data indicated must also be understood as being general in nature. For specific applications, please contact the MGM staff.

# technical data two speed motors - two windings

Motor type	Power (kW)	RPM	In (A) 400 V	cos φ	Tn (Nm)	Ts / Tn	Is / In	DC brake In (mA)	Z <sub>0</sub> (starts /hour)	Moment of inertia Jx 10 <sup>-4</sup> Kg·m <sup>2</sup>	Max Brake torque (Nm)	A-Sound pressure dB (A)	Weight (Kg)
4/6 pole													1500 / 1000 r.p.m.
BMDA 71 C4/6	0.18 0.11	1415 930	0.60 0.50	0.76 0.66	1.21 1.13	1.9 2.0	3.0 2.3	200	14500 19500	10.82	5	45 45	8.5
BMDA 80 A4/6	0.25 0.18	1430 930	0.85 0.80	0.79 0.71	1.67 1.85	2.2 1.8	4.3 3.0	160	8250 11500	19.05	10	47 47	12.0
BMDA 80 B4/6	0.37 0.25	1430 930	1.05 0.95	0.79 0.71	2.47 2.57	2.2 1.8	4.3 3.0	160	1300 10300	22.86	10	47 47	13.0
BMDA 90 SA4/6	0.55 0.37	1420 950	1.60 1.45	0.78 0.62	3.70 3.72	1.9 2.1	3.8 3.3	190	6900 9750	31.52	20	55 54	16.5
BMDA 90 LB4/6	0.75 0.55	1420 950	2.20 1.90	0.78 0.62	5.04 5.53	2.0 2.1	3.8 3.3	190	5700 8200	41.67	20	55 54	19.5
BMDA 100 LA4/6	1.1 0.8	1445 955	3.00 2.40	0.76 0.71	7.27 8.00	2.0 2.1	5.3 4.4	250	3100 4400	80.76	40	57 56	26
BMDA 100 LB4/6	1.5 1.1	1440 950	3.90 3.30	0.75 0.68	9.95 11.06	2.0 2.1	5.2 4.4	250	3000 4200	92.55	40	57 56	28
BMDA 112 MB4/6	2.0 1.3	1385 930	4.40 3.50	0.88 0.75	13.79 13.35	2.6 2.1	5.3 4.4	470	1550 3300	200.60	60	75 61	39
BMDA 132 SB4/6	2.2 1.5	1440 950	5.10 4.40	0.78 0.69	14.59 15.08	2.9 2.6	7.0 5.5	600	360 600	304.90	100	75 62	66
BMDA 132 MA4/6	3.0 2.2	1440 950	6.40 6.00	0.81 0.71	19.90 22.12	2.7 2.4	7.0 5.0	600	360 600	360.70	100	75 62	71
BMDA 132 MB4/6	3.7 2.5	1440 950	8.20 7.00	0.78 0.69	24.54 25.13	2.9 2.6	7.0 5.5	600	300 550	467.70	100	75 62	82
BMDA 160 MB4/6	5.5 3.7	1390 940	11.10 8.90	0.93 0.81	37.79 37.59	2.5 2.3	5.8 5.2	700	240 420	867.00	150	63 59	138
BMDA 160 LB4/6	7.5 5.0	1390 940	15.20 12.20	0.93 0.81	51.53 50.80	2.5 2.3	6.0 5.2	700	240 420	1160.00	150	63 59	156
4/12 pole													1500 / 500 r.p.m.
<b>S3 40%</b>													
BMDA 80 A4/12	0.25 0.05	1425 435	0.85 0.60	0.77 0.663	1.68 1.10	1.8 1.9	3.7 1.6	160	4300 8000	19.05	10	47 43	12.0
BMDA 80B4/12	0.37 0.07	1425 435	1.05 0.75	0.77 0.63	2.48 1.54	1.8 1.9	3.7 1.6	160	4200 8000	22.86	10	47 43	13.0
BMDA 90 SA4/12	0.40 0.13	1360 380	1.25 1.05	0.73 0.59	2.81 3.27	2.5 2.0	3.5 1.6	190	3200 6100	31.52	20	55 44	16.5
BMDA 90 LA4/12	0.55 0.18	1400 400	1.65 1.20	0.76 0.64	3.75 4.30	2.5 1.8	3.5 1.6	190	3000 5900	41.67	20	55 44	19.5
BMDA 90 LB4/12	0.75 0.22	1370 400	2.05 1.60	0.76 0.65	5.23 5.25	2.5 2.0	3.5 1.6	190	2850 5700	48.21	20	55 44	20.5
BMDA 100 LA4/12	0.90 0.25	1440 450	2.30 2.10	0.76 0.50	5.97 5.31	2.2 1.8	5.3 1.7	250	1950 4700	80.76	40	57 47	26
BMDA 100 LB4/12	1.10 0.35	1440 450	2.80 2.60	0.76 0.50	7.30 7.43	2.2 1.8	5.3 1.7	250	1850 4500	92.55	40	57 47	28
BMDA 112 MB4/12	1.50 0.45	1420 440	3.40 2.40	0.84 0.55	10.09 9.77	2.2 2.0	6.0 2.2	470	780 4300	200.60	60	75 61	39
BMDA 132 SA4/12	2.50 0.80	1440 440	5.40 3.80	0.81 0.53	16.58 17.36	2.7 1.6	7.0 2.4	600	400 1100	304.90	100	75 62	67
BMDA 132 MA4/12	3.00 1.00	1440 440	6.40 4.50	0.81 0.53	19.90 21.70	2.7 1.6	7.0 2.4	600	400 1100	360.70	100	75 62	71
BMDA 132 MB4/12	4.00 1.30	1140 440	8.50 5.90	0.81 0.55	33.51 28.22	2.7 1.6	7.0 2.4	600	400 1100	467.70	100	75 62	82
BMDA 160 MB4/12	4.80 1.60	1425 455	10.00 7.20	0.89 0.57	32.17 33.58	2.8 2.0	7.5 3.0	700	300 850	867.00	150	63 61	138
BMDA 160 LB4/12	7.30 2.40	1410 445	15.20 10.10	0.90 0.61	49.44 51.51	2.8 2.0	7.0 3.0	700	300 850	1160.00	150	63 61	156

1. Motor characteristic values reported in the tables refer to continuous duty (S1), except for 4/12 pole motors 50 Hz frequency, ambient temperature max. 40 °C, altitude up to 1000 m. above sea level operating condition.  
 2. The expressed brake torque is the max admissible one. Brake current consumption values refer to a rated voltage of 230V AC single-phase.  
 3. The table shows the sound pressure noise level, measured at one metre range from the motor according to the Acurve (ISO 1680). The shown noise levels refer to motor no-load operating condition and should

be regarded with a tolerance of ± 3dB.  
 4. The brake torque indicated on the chart is the maximum one that can be reached.  
 5. Z<sub>0</sub> is the max number of no-load starts. It is meant for calculation purposes only, and is used to obtain the max number of starts with load according to the formula expressed at page 42. The number of starts with load (Z<sub>load</sub>) is indicative and it has to be operatively tested for confirmation. The use of thermal protectors is strongly recommended when the oper-

ative number of starts is close to the calculated Z<sub>load</sub>. It is necessary to verify the max permissible brake energy dissipation and the max permissible RPM for applications with high moment of inertia.  
 6. MGM keeps the data provided as up-to-date and correct as possible. Since the products are subject to changes and improvements, the data indicated cannot be considered binding. The data indicated must also be understood as being general in nature. For specific applications, please contact the MGM staff.



Size 56 63 71 80 90S 90L 100L 112M 132S 132M 160M 160L 180 200 225S 225M

<b>A</b>	90	100	112	125	140	140	160	190	216	216	254	254	279	318	356	356
<b>B</b>	71	80	90	100	100	125	140	140	140	178	210	254	279	305	286	311
<b>C</b>	36	40	45	50	56	56	63	70	89	89	108	108	121	133	149	149
<b>D</b>	9	11	14	19	24	24	28	28	38	38	42	42	48	55	60	60
<b>d</b>	M3	M4	M5	M6	M8	M8	M10	M10	M12	M12	M16	M16	M16	M20	M20	M20
<b>E</b>	20	23	30	40	50	50	60	60	80	80	110	110	110	110	140	140
<b>Fa</b>	6.6	9.5	9.5	11.5	11.5	11.5	14.5	14.5	14.5	14.5	18.5	18.5	18.5	18.5	18.5	18.5
<b>Fb</b>	M5	M5	M6	M6	M8	M8	M8	M8	M10	M10	-	-	-	-	-	-
<b>f</b>	3	4	5	6	8	8	8	8	10	10	12	12	14	16	18	18
<b>g</b>	7.2	8.5	11	15.5	20	20	24	24	33	33	37	37	42.5	49	53	53
<b>H</b>	56	63	71	80	90	90	100	112	132	132	160	160	180	200	225	225
<b>h</b>	3	4	5	6	7	7	7	7	8	8	8	8	9	10	11	11
<b>I</b>	6	7	7	10	10	10	12	12	12	12	14.5	14.5	14.5	18.5	18	18
<b>K</b>	11	10.5	10.5	14	14	14	16	16	22	22	24	24	24	30	18	18
<b>L</b>	99	130	145	162	171	196	-	-	-	-	-	-	-	-	-	-
<b>L1</b>	-	166	182	194	207	232	254	262	294	339	373	395	420.5	445.5	530	530
<b>Ma</b>	100	115	130	165	165	215	215	265	265	300	300	300	350	400	400	400
<b>Mb</b>	65	75	85	100	115	115	130	130	165	165	-	-	-	-	-	-
<b>Na</b>	80	95	110	130	130	180	180	230	230	250	250	250	300	350	350	350
<b>Nb</b>	50	60	70	80	95	95	110	110	130	130	-	-	-	-	-	-
<b>Oa</b>	3	3	3.5	3.5	3.5	3.5	4	4	4	4	5	5	5	5	5	5
<b>Ob</b>	2.5	2.5	2.5	3	3	3	3.5	3.5	3.5	3.5	-	-	-	-	-	-
<b>Pa</b>	120	140	160	200	200	250	250	300	300	350	350	350	400	450	450	450
<b>Pb</b>	80	90	105	120	140	140	160	160	200	200	-	-	-	-	-	-
<b>Q</b>	230	260	295	334	360	385	435	470	565	604	716	760	863	888	950	950
<b>R</b>	75	80	80	80	98.5	98.5	-	-	-	-	-	-	-	-	-	-
<b>R1</b>	-	135	135	135	170	170	170	170	199	199	268	268	268	268	327	327
<b>S</b>	8	10	10	12	12	12	14	14	15	15	15	15	19.5	15	20	20
<b>V</b>	7	7	8	9.5	10.5	10.5	12.5	13.5	16	16	21	21	24	24	32	32
<b>W</b>	93	97	105	113	127	127	-	-	-	-	-	-	-	-	-	-
<b>W1</b>	-	111	121	130	148	148	162	176	258	258	309.5	309.5	269.5	269.5	324	324
<b>Y</b>	110	121	136	153	178	178	198	219.5	255	255	293	293	355	355	433	433
<b>Z</b>	75	75	75	75	98.5	98.5	-	-	-	-	-	-	-	-	-	-
<b>Z1</b>	-	86	86	86	112	112	112	112	151	151	167	167	167	167	202	202

\* 225S-225M 2 pole D=55 E=110

### Shaft End

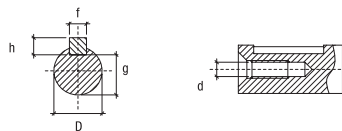

### B3

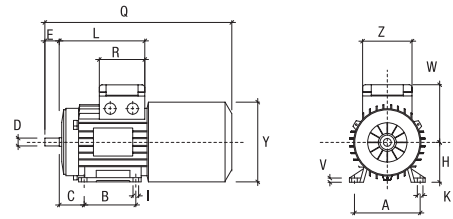

### B5

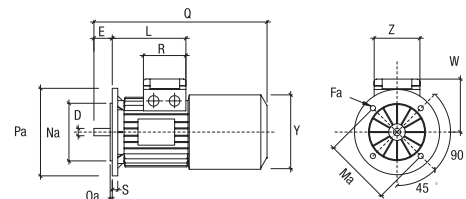

### B14

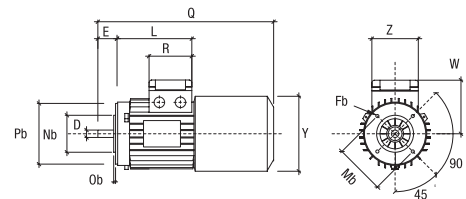

### Double Terminal Board Box

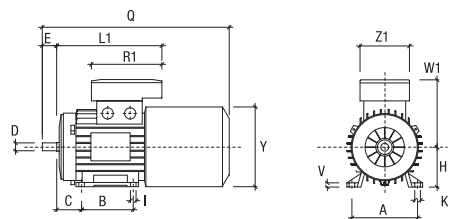

### 160-225 B3

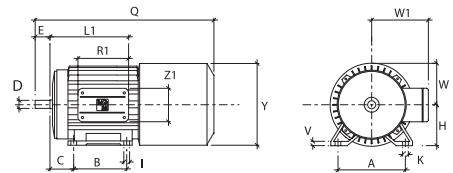

### Notes

Cable glands are	M 16 on size 56 up to 63
	M 20 on size 71 up to 80
	M 25 on size 90 up to 112
	M 32 on size 132
	M 40 on size 160 up to 200
	M 50 on size 225

## traverse motors with progressive start and stop

A few problems such as the swinging of suspended loads, slipping of trolley wheel on rails, the breakage of some delicate mechanisms can occur on traverse applications. All these problems can be solved using progressive start/stop systems such as clutches, hydraulic couplings, slip-ring motors or soft start devices. Experience has shown that progressive start/stop PV brake motor is a valid alternative to all the other adducted systems. Traverse motors are provided with a flywheel whose dimension and weight are calculated in order to have an adequate moment of inertia. The ratio of rated torque to starting (locked rotor) torque is calculated in order to achieve the best progressive performance. The flywheel accumulates energy during the start and gives it back during the stop resulting in a progressive change of the rotating speed. PV series motors don't need adjustments with load change or any special maintenance and the progressive action is directly proportional to the load increase. During the planning stage it is necessary to choose carefully the proper motor power as an insufficient power could cause overheating while a too powerful motor could reduce the effect of the flywheel progression.

The flywheel doesn't cause any problems in case of start/stop in rapid succession (positioning of loads) but not for a long period of time in order to avoid overheating. The presence of a special rotor P allows to obtain reduced starting current ( $I_s$ ). BAPV series motors provide a reduced brake torque, resulting in a really progressive action. The brake torque of BAPV motors is about the half of the corresponding BA standard brake motors while BM and BMPV series motors have the same brake torque.

The progressive start/stop of a BAPV motor is obtained by a flywheel strongly secured to the motors shaft in the place of the normal brake disc of the BA series while in a BMPV motor this progression is obtained by means of a cast iron cooling fan which replaces the thermoplastic one.

PV series motors are available with the following features or option:

- separate brake supply
- manual brake release
- suitable for mounting in any position (vertical, horizontal, etc.)
- two speeds

The table below shows the moment of inertia increase ( $Kg\cdot m^2$ ) for BAPV and BMPV series.

Motor Type	63	71	80	90	100	112	132	160
BAPV	-	$2.97 \cdot 10^{-3}$	$6.78 \cdot 10^{-3}$	$1.11 \cdot 10^{-2}$	$1.82 \cdot 10^{-2}$	$2.89 \cdot 10^{-2}$	$5.8 \cdot 10^{-2}$	$14.3 \cdot 10^{-2}$
BMPV	$3.1 \cdot 10^{-4}$	$1.93 \cdot 10^{-3}$	$3.12 \cdot 10^{-3}$	$9.97 \cdot 10^{-3}$	$1.52 \cdot 10^{-2}$	$1.52 \cdot 10^{-2}$	-	-

The total moment of inertia of a chosen motor is the moment of inertia of a standard brake motor (see motors technical data) plus the flywheel moment of inertia (shown in table above).

Example:

$$\text{moment of inertia of BAPV 71 B4} = \text{moment of inertia of BA 71 B4} + \text{flywheel type BAPV 71 B4 moment of inertia} = 8.1 \cdot 10^{-4} + 2.97 \cdot 10^{-3} = 3.78 \cdot 10^{-3} \text{ Kg}\cdot\text{m}^2$$

The table below shows the maximum brake torque (Nm) for BMPV with DC brake and BAPV motors with AC brake or DC brake:

Motor type	63	71	80	90	100	112	132	160
BMPV	5	5	10	20	40	60	-	-
BAPV - A.C.	-	7	9	19	25	40	75	95
BAPV - D.C.	-	4.5	7.5	15	21	30	60	77

**BAPV series**

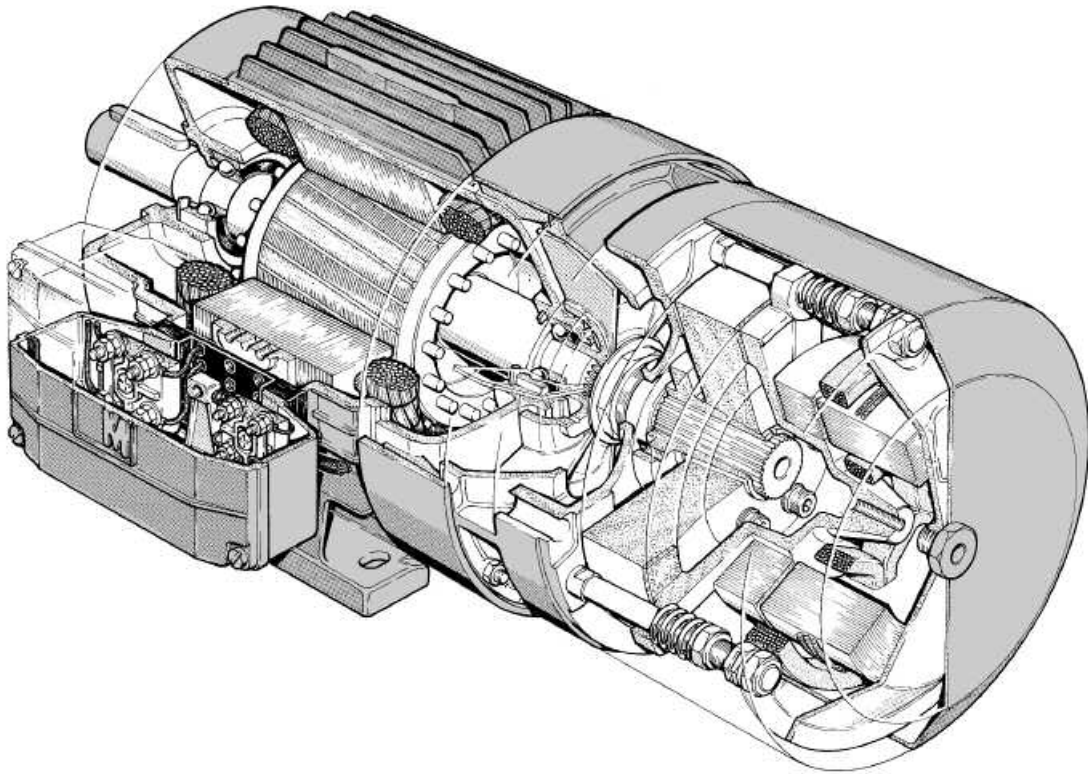

**BMPV series**

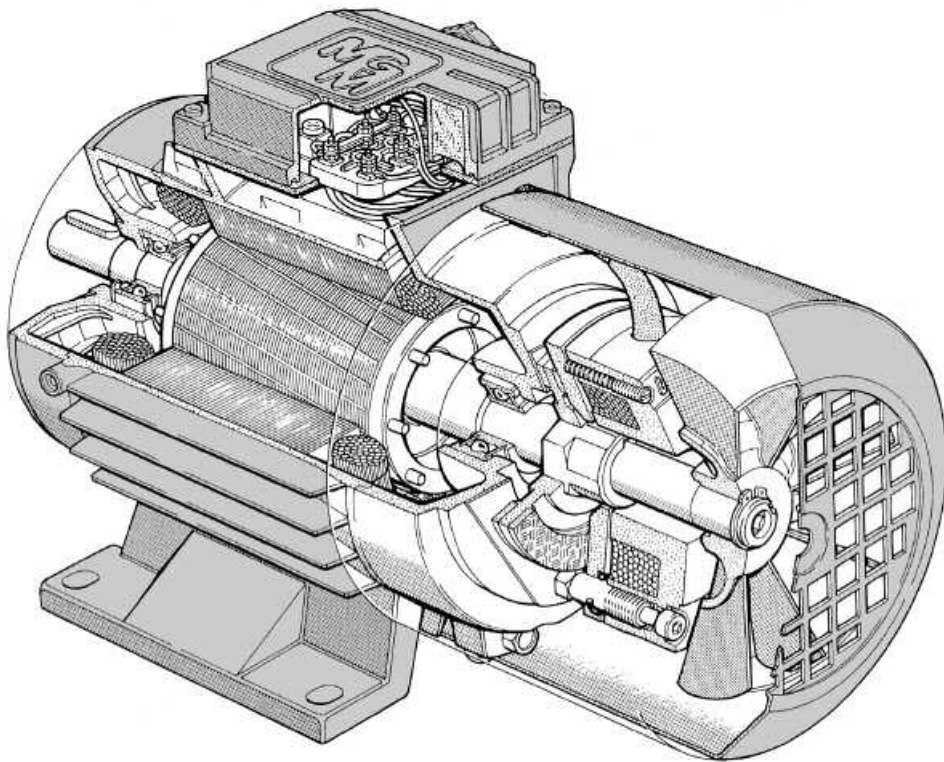

## BAH Series 80÷315

BA brake motors come manufactured as BAH serie-motors starting from frame size 225 up to 315mm and, on request, starting from size 80 up to 200mm.

The BAH serie-motors have the same characteristics of the BA serie-motors. The difference essentially consists in the casing of the brake assembly designed to give greater strenght and protection against the entry of dust and liquids (IP degree). The BAH serie-motors are supplied as standard with IP55 protection degree and, on request, with IP56-65-66 protection degree.

- 17 - Brake Friction surface
- 18 - Spring
- 19 - Brake Adjuster
- 20 - Brake Torque Adjuster Locknut
- 21 - Air Gap Adjusting Nut
- 22 - Brake Coil Locknut
- 23 - Brake disc
- 24 - Brake Moving Element
- 25 - Brake coil
- 26 - Brake Cover (BAH)
- 60 - Air Gap
- 117 - Brake Cover Fixing Screw (BAH 80÷112)
- 119 - Brake Cover Closing Cap BAH
- 125 - Brake Cover Fixing Nut (BAH 132÷315)

Starting from frame size 160 casing, shields, flanges, brake friction surface and the brake protective cover are made of cast iron in order to provide a greater mechanical strenght and to be suitable for harsh environment (i.e. marine application). Upon request, starting from frame size 225, the motor body can be made of ductile cast iron.

Starting from frame size 160 shafts are made of 39NiCrMo3 steel.

The standard brake release is the locking type (on request it's possible to have the unlocking one).

The locking type brake release is realized by means of 1 central screw for sizes 80÷112, 2 side screws for sizes 132÷315.

The following options are available upon request:

- special shaft dimensions (DE-side) or double extended shaft (NDE-side);
- encoder;
- brake release system (unlocking type);
- anti-condensation heaters on the motors and/or on brake coils;
- thermistors (PTC) OF Bi-Metallic (PTO) thermal protectors;
- non-ventilated execution (BAHS).

## BAH Series



## Brake assembly BAH 80÷112

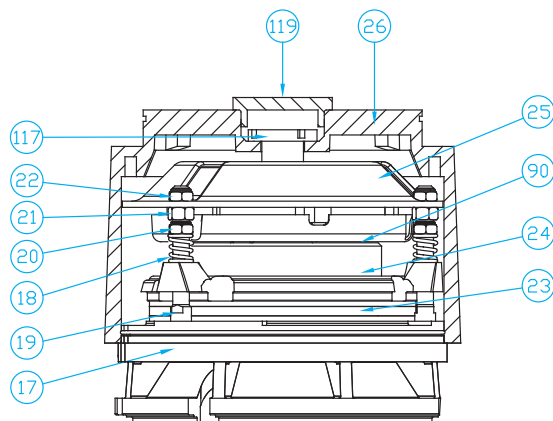

## Brake assembly BAH 132÷315

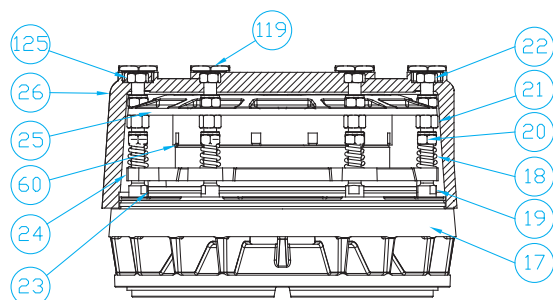

## Brake release system for BAH 132÷315

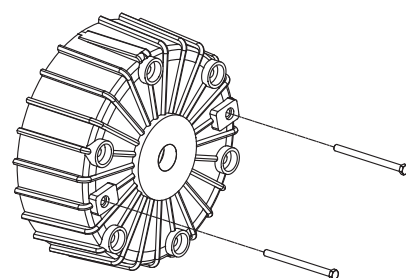

**BAH series**

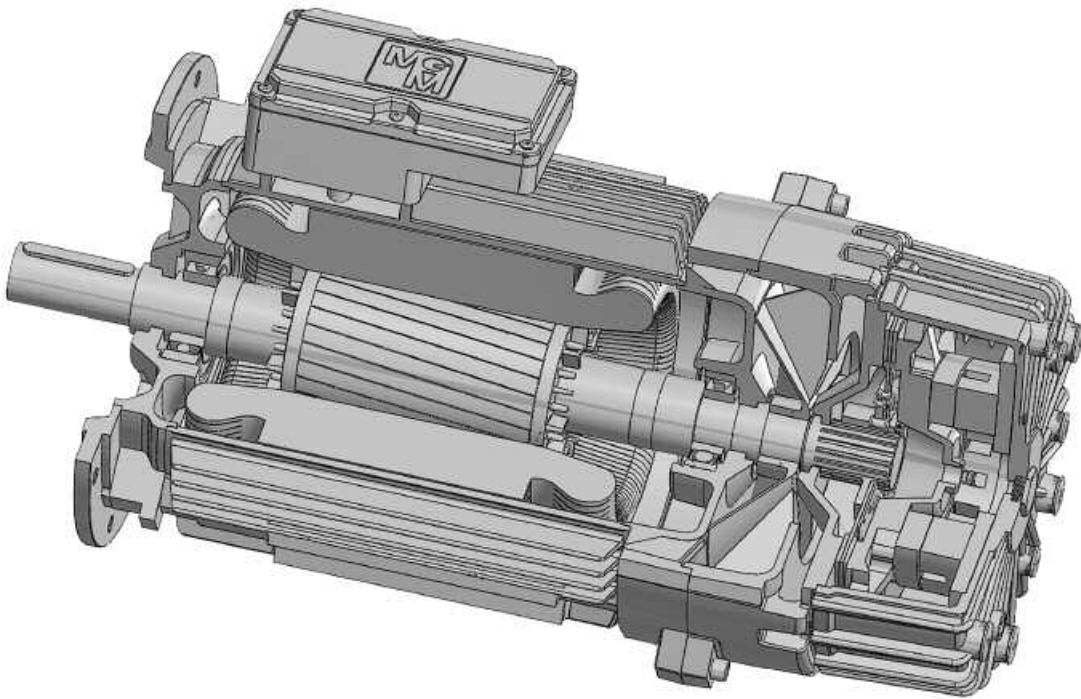

**BAHS series**

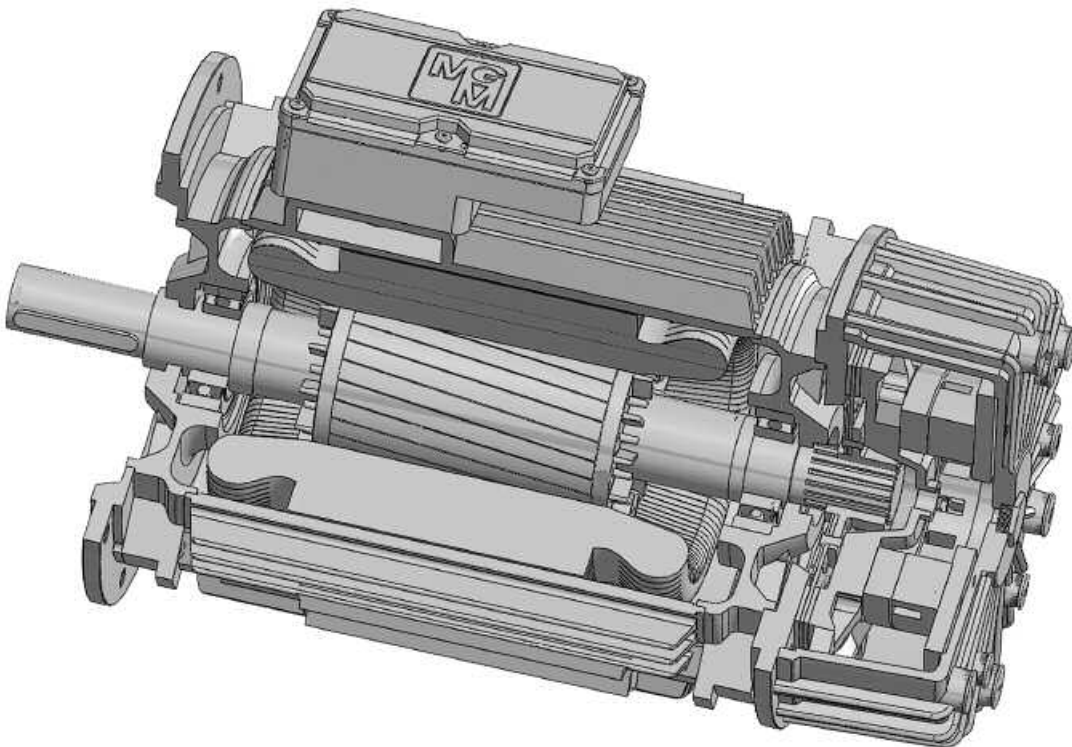

BAPK series brake motors are available starting from 100 up to 225 frame size. Powers and poles are the same as the BA series motors (see BA technical data). BAPK series motors have the same motor construction as BA series motors but present some special parts. Single and most of the two speed BAPK motors are fitted with a special rotor (P rotor) that increases the starting torque (locked rotor) by 20% about and that reduces the starting current (locked rotor) by 10% about.

The brake assembly of a BAPK motors is just the same of the standard BA series with 2 braking surfaces but with a special brake disc (K) with steel hub. The BAPK series motors are equipped as standard with an AC brake.

Feet are frame integrated on B3 mounting (foot mounted) and not simply attached to the frame. This feature guarantee best reliability of brake motors for hoist application. Shields and flanges are made of cast iron. Frame is made of aluminium from 100 up to 132 frame size (132 cast iron frame is available on request) while it is made of cast iron starting from 160 frame size. Dimensions are the same as the BA series (dimensions sheet pag. 39). To purchase BAPK series motors the writing BAPK has to be clearly stated in the order (i.e. BAPK 112MB4).

### K brake disc

The K brake disc is provided as standard on motors starting from 160 frame size while it's available on request on motors from 90 up to 132 frame size. As for the case of the BA standard brake, which is made of a special aluminium/thermoplastic material, the K brake disc has two friction surfaces and it has a nucleus and a steel hub, which guarantee a higher sturdiness and moment of inertia. K brake disc is strongly recommended for hoisting application, safety application or under high environment temperature (50° C or above).

K brake disc has a shorter life than the standard brake disc as a consequence of the increased moment of inertia therefore it's advisable to use the standard brake disc on heavy start/stop duty cycle application where the K disc is not necessary. To purchase motors with K brake disc, the writing BAK has to be clearly stated in the order (i.e. BAK 112 MB4). For further information please contact MGM.

## premium brake torque motors - BAF series

BAF series motors are brake motors providing a very high brake torque. BAF series motors are particularly suitable for those applications where it's needed to keep the motor locked up also under a very high turning moment. The required high value of static brake torque is achieved by the use of a double brake disc (BAF series). BAF series motors are provided with AC brake. BAF motors are available starting from 100 up to 200 frame size. The table below shows the BAF series brake torque values (50% more than standard BA series).

Motor type	BAF 100	BAF 112	BAF 132	BAF 160	BAF 180	BAF 200
Brake Torque Max (Nm)	75	120	225	285	450	450

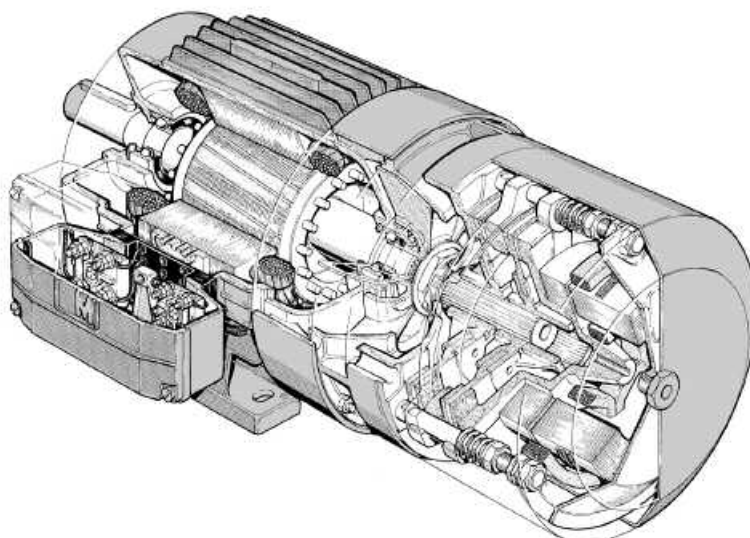

AC electric motors operating in non standard conditions (low frequency inverter duty, long overcharge periods, heavy duty cycles) could need additional cooling servo-fan. BASV series motors with forced cooling are provided with two additional cooling servo-fans fixed on the motor frame.

This cooling system (MGM patent), compared to the traditional solution, has the following features:

1. The standard self cooling fan inside the motor is kept additionally to the cooling servo-fans.
2. The whole heating surface is increased as the fan fixing system is itself a heat dissipation element additional to the existing fins on the frame.
3. Low noise level.
4. No additional motor length compared to the standard one.
5. Manual brake release with manual rotation.
6. Uniform winding cooling along the whole motor length.
7. The brake friction surface is cooled on the motor side.

Where the forced cooling is used to limit the operating temperature in heavy start/stop duty application, it should be noted that the efficiency of the forced cooling increases with the number of poles of the motor. It's hard to estimate the amount of hot air removed by the forced cooling fans but it can be roughly said that it is the same as the air removed by the standard servo-fan of a 4 pole motor operating at 50 Hz.

It is advisable to use thermal protectors in heavy operating conditions. The table below shows the technical details of fans supplied at 1~230V single-phase and 400 three-phase. The servo-fans can be supplied both at 50Hz or 60Hz. On request forced cooling fans can be provided with different voltage supply.

Motor type	Dim X (mm)	Dim Y (mm)	Dim L (mm)	Volt	Watt
BASV 71	210	107	102	1~230	2x16
BASV 80	230	108	120	1~230	2x16
BASV 90	270	129	129	1~230	2x20
BASV 100	280	129	134	1~230	2x20
BASV 112	300	142	142	1~230	2x20
BASV 132	348	169	169	1~230	2x20
BASV 160	431	184	190	1~230	2x36
BASV 180	485	211	211	1~230	2x36
BASV 200	485	211	211	1~230	2x36
BASV 225	522	221	221	1~230	2x36

**BASV Series**

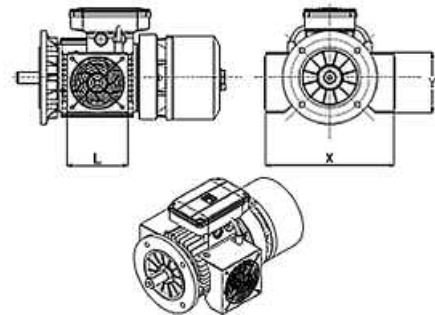

It is also possible to have the motors of the BM series in the BMAV version with axial ventilation (axial servo-fan located in the rear part of the motor, replacing the standard motor fan).

Motor type	Dim Q (mm)	Volt	Watt
BMAV 56	250	1~230	16
BMAV 63	280	1~230	16
BMAV 71	315	1~230	16
BMAV 80	364	1~230	16
BMAV 90	390	1~230	36
BMAV 100	415	1~230	36
BMAV 112	465	1~230	36
BMAV 132	604	3~400	93
BMAV 160	734	3~400	93
BMAV 180	825	3~400	123
BMAV 200	825	3~400	123
BMAV 225	1065	3~400	123

**BMAV Series**

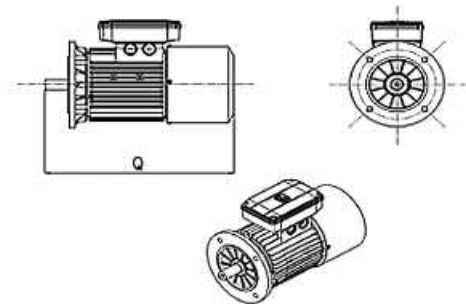

## built-in encoder motors

### BAE-BAHE and BMEAV series

Two motors series with built-in encoder are available:

**BAE-BAHE series:** asynchronous three phase fan cooled brake motors with built-in encoder and frame size from 71 up to 280. The encoder is located at the Non-Drive end (NDE side) in a safe place protected by a well closed cover. Forced ventilation is available on request (BAESV-BAHESV series). The motor is provided as standard with separate brake supply. The brake coil is AC as standard, while DC is available on request. The brake hand release is not available for BAE series while is available on request for BAHE series motors (locking or unlocking type).

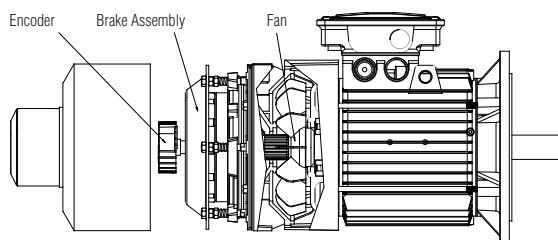

**BMEAV series:** asynchronous three phase brake motors with DC brake with axial forced ventilation, built-in encoder and frame size from 63 up to 225. The encoder is located at the NDE side between the brake coil and the servo fan.

The motor is supplied as standard with separate brake supply. Brake hand release on side (unlocking type) is available on request.

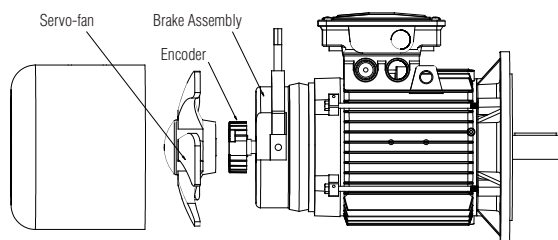

Motors of the **BAE** and **BMEAV** series are designed to be suitable for inverter use; precise dynamic balancing along with an accurate motor insulation system are adopted in order to withstand the greater electrical and mechanical stress. The mechanical coupling is the same of a standard motors (special shaft and flange are available on request), wirings are very simple to be made: power and electrical signal duty are separated. Upon request, the motors can be supplied with the cCSAus approval.

#### Encoder

To identify exactly the needed encoder, the following characteristics have to be indicated:

- Encoder type (incremental or absolute)
- Resolution (PPR)
- Zero pulse
- Encoder supply voltage
- Electronic output configuration
- IP protection degree (please consider that for the BAE series the encoder is also protected by a well closed cover)
- Interface type
- Code (only for absolute encoders)
- Single turn or Multi turn (only for absolute encoders)

The output cable is provided as standard without connector (floating cable). On request a connector can be supplied.

Please contact MGM for further information.



Size	71	80	90S	90L	100L	112M	132S	132M	160M	160L	180L	200L	225S	225M
A	112	125	140	140	160	190	216	216	254	254	279	318	356	356
B	90	100	100	125	140	140	140	178	210	254	279	305	286	311
C	45	50	56	56	63	70	89	89	108	108	121	133	149	149
D*	14	19	24	24	28	28	38	38	42	42	48	55	60	60
d	M5	M6	M8	M8	M10	M10	M12	M12	M16	M16	M16	M20	M20	M20
E*	30	40	50	50	60	60	80	80	110	110	110	110	140	140
Fa	9.5	11.5	11.5	11.5	14.5	14.5	14.5	14.5	18.5	18.5	18.5	18.5	18.5	18.5
Fb	M6	M6	M8	M8	M8	M8	M10	M10						
f	5	6	8	8	8	8	10	10	12	12	14	16	18	18
g	11	15.5	20	20	24	24	33	33	37	37	42.5	49	53	53
H	71	80	90	90	100	112	132	132	160	160	180	200	225	225
h	5	6	7	7	7	7	8	8	8	8	9	10	11	11
I	7	10	10	10	12	12	12	12	14.5	14.5	15	18.5	18	18
K	10.5	14	14	14	16	16	22	22	24	24	24	30	18	18
L1	184	194	207	232	254	262	294	339	373	395	420	446	440	440
Ma	130	165	165	165	215	215	265	265	300	300	300	350	400	400
Mb	85	100	115	115	130	130	165	165						
Na	110	130	130	130	180	180	230	230	250	250	250	300	350	350
Nb	70	80	95	95	110	110	130	130						
Oa	3.5	3.5	3.5	3.5	4	4	4	4	5	5	5	5	5	5
Ob	2.5	3	3	3	3.5	3.5	3.5	3.5						
Pa	160	200	200	200	250	250	300	300	350	350	350	400	450	450
Pb	105	120	140	140	160	160	200	200						
Q	415	451	483	507	558	576	677	715	803	847	931	956	1077	1077
q	76	76	76	76	76	76	76	76	76	76	76	76	89	89
R1	135	135	170	170	170	170	199	199	268	268	268	268	327	327
S	10	12	12	12	14	14	15	15	15	15	15	15	20	20
V	8	9.5	10.5	10.5	12.5	13.5	16	16	21	21	24	24	32	32
W									165	165	188	188	224	224
W1	121	130	148	148	162	176	210	210	246	246	266	266	341	341
Y	145	160	180	180	196	218	265	265	324	324	357	357	430	430
Y1	121	121	121	121	121	121	121	121	121	121	121	121	158	158
Z1	86	86	112	112	112	112	151	151	167	167	167	167	202	202

\* 225S-225M 2 pole D=55, E=110

**BAE B3**

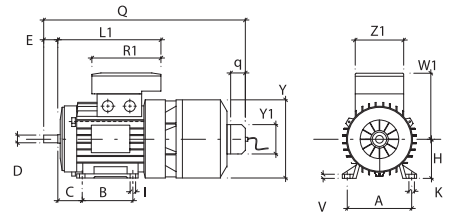

**BAE B5**

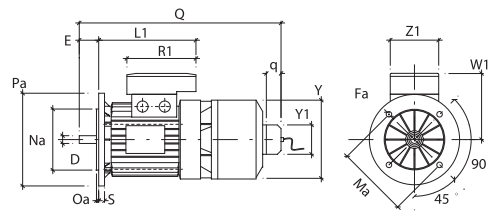

**BAE B14**

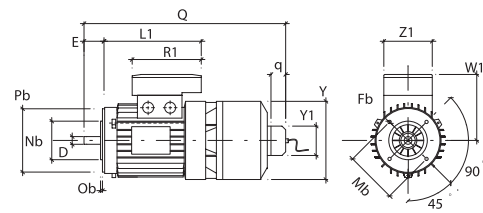

**BAE 160/180/200/225 B3**

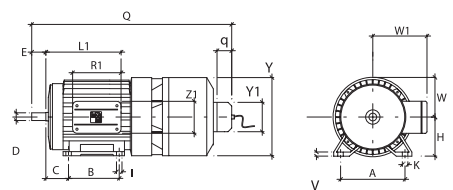

**BAE series**



**Shaft End**

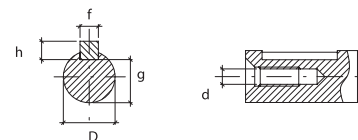

Please contact MGM for further information regarding the dimensions of the motors series BAHE with 250-280-315 frame sizes.

**BMEAV series dimensions**

Size	63	71	80	90S	90L	100L	112M	132S	132M	160M	160L
A	100	112	125	140	140	160	190	216	216	254	254
B	80	90	100	100	125	140	140	140	178	210	254
C	40	45	50	56	56	63	70	89	89	108	108
D	11	14	19	24	24	28	28	38	38	42	42
d	M4	M5	M6	M8	M8	M10	M10	M12	M12	M16	M16
E	23	30	40	50	50	60	60	80	80	110	110
Fa	9.5	9.5	11.5	11.5	11.5	14.5	14.5	14.5	14.5	18.5	18.5
Fb	M5	M6	M6	M8	M8	M8	M8	M10	M10		
f	4	5	6	8	8	8	8	10	10	12	12
g	8.5	11	15.5	20	20	24	24	33	33	37	37
H	63	71	80	90	90	100	112	132	132	160	160
h	4	5	6	7	7	7	7	8	8	8	8
I	7	7	10	10	10	12	12	12	12	14.5	14.5
K	10.5	10.5	14	14	14	16	16	22	22	24	24
L1	166	184	194	207	232	254	262	294	339	373	395
Ma	115	130	165	165	165	215	215	265	265	300	300
Mb	75	85	100	115	115	130	130	165	165		
Na	95	110	130	130	130	180	180	230	230	250	250
Nb	60	70	80	95	95	110	110	130	130		
Oa	3	3.5	3.5	3.5	3.5	4	4	4	4	5	5
Ob	2.5	2.5	3	3	3	3.5	3.5	3.5	3.5		
Pa	140	160	200	200	200	250	250	300	300	350	350
Pb	90	105	120	140	140	160	160	200	200		
Q	310	345	384	410	435	485	520	625	664	690	734
R1	135	135	135	170	170	170	170	199	199	268	268
S	10	10	12	12	12	14	14	15	15	15	15
V	7	8	9.5	10.5	10.5	12.5	13.5	16	16	21	21
W										155	155
W1	111	121	130	148	148	162	176	210	210	246	246
Y	121	136	153	178	178	198	219.5	255	255	310	310
Z1	86	86	86	112	112	112	112	151	151	167	167

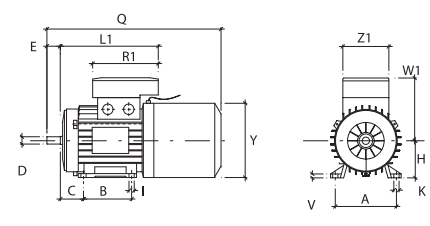
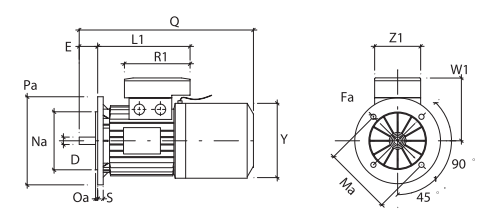
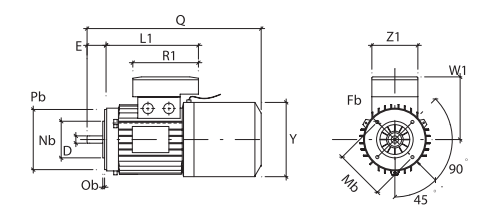
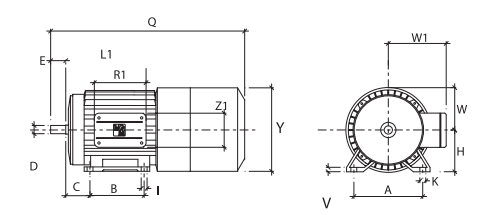
**BMEAV B3**

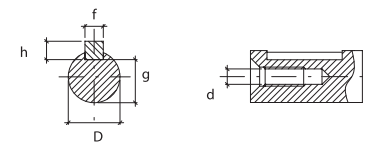
**BMEAV B5**

**BMEAV B14**

**BMEAV 160/180/200/225 B3**

**BMEAV series**

**Shaft End**

Please contact MGM for further information regarding the dimensions of the motors series BMEAV with 180-200-225 frame sizes.

## R series

The "R" Series is made up of a new generation of asynchronous standard motors (SMR) or brake motors (BAR or BMR), 4 and 6 poles and IEC frame sizes from 56 up to 132. Available nominal torques range is from 0.4Nm to 37Nm on 4 pole motors while it's from 3.88Nm to 54.71Nm on 6 pole motors. **R series motor is designed to be controlled by inverter only.** The reference frequency at a voltage of 400V is 120Hz instead of 400V 50Hz. The special technology allows to the R series motors to have the following features:

- constant torque from 3 to 120Hz
- torque close to the nominal one at 0 rpm (only in a closed loop vector system)
- Higher Power Density (same power in smaller motor sizes)
- reduced moment of inertia compared to a motor with same power (high dynamics)
- faster acceleration and deceleration times
- excellent behaviour during transients (4 poles) and in continuous duty (6 poles)
- optimized for use with different types of inverters in the market
- balancing suited for operation with high acceleration
- standard motor sizes and mounting
- low noise
- standard electrical wiring
- encoder option available
- user friendly product (connectors not needed)

On standard, R series motors are equipped with thermal protectors, rotor and stator magnetic steel with advanced magnetic properties, motor winding specifically designed and impregnated for operation at high frequency, higher grade rotor balancing and bearings resistant to high rotation speed. All the options of standard motors series are also available for the R Series  
IP54 enclosure rating is factory standard for brake motors while IP55 for standard motors. Enclosure rating up to IP56 is available on request. All motors can be provided either with an encoder or encoder ready.

### Low moment of inertia (at equal power)

Thanks to the diameter of the bottom rotor, the reduction in the moment of inertia for a motor in the new series "R" is very significant compared to one with equal power and traditional polarity. This means lower energy demand during transients and definite improvement in the dynamic qualities. The examples below show a comparison in the moment of inertia for two motors:

- standard motor (without brake) 0,75 kW (SM 80 B4)  $12,39 \times 10^{-4}$  Kg $m^2$
- "R" series motor (without brake) 0,72 kW (SMR 63 D4)  $3,68 \times 10^{-4}$  Kg $m^2$
- brake motor standard version 2,2 kW (BA 100 LA4)  $51,14 \times 10^{-4}$  Kg $m^2$
- "R" series brake motor 2,16 kW (BAR 80 D4)  $18,3 \times 10^{-4}$  Kg $m^2$

### Constant torque

The torque remains constant at the nominal value and from a few Hz up to 120Hz. Once over 120Hz, the motor delivers constant power up to 3600 for 4 poles and 2400 for 6 poles.

The torque value with locked rotor can reach about 100% of the nominal torque. The greater extension of the speed adjustment field in which the motor retains the capacity to provide constant torque, allows a better control of the motor and machine on which it is applied.

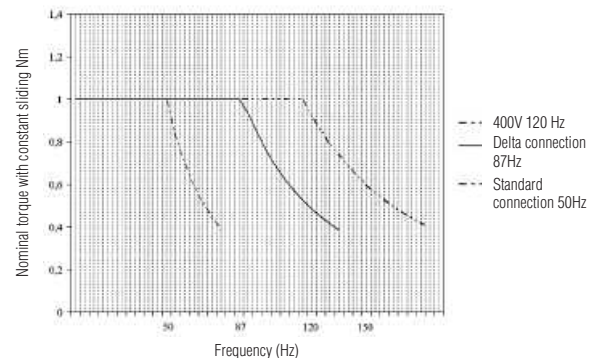

Motor type	Inverter power supply [V]	Nominal torque [Nm]	Nominal current [I]	Synchronous speed [Rpm]	Maximum speed [Rpm]	Nominal power [W]	Moment of inertia [10 <sup>-4</sup> kgm <sup>2</sup> ] SMR	Moment of inertia [10 <sup>-4</sup> kgm <sup>2</sup> ] BMR	Moment of inertia [10 <sup>-4</sup> kgm <sup>2</sup> ] BAR
<b>6 pole</b>									
80 A	400	3,88	3,0	2400	3600	900	18,60	19,0	23,4
80 B	400	5,84	4,3	2400	3600	1320	22,41	22,9	27,2
90 SA	400	7,87	5,5	2400	3600	1800	29,80	31,5	35,9
90 LA	400	11,54	7,7	2400	3600	2640	39,95	41,7	46,1
90 LB	400	13,64	9,4	2400	3600	3120	46,38	48,1	53,0
100 LA	400	15,40	9,4	2400	3600	3600	78,26	80,8	87,4
100 LB	400	19,20	12	2400	3600	4440	88,05	92,5	99,2
112 MB	400	22,23	12,5	2400	3600	5280	145,38	200,6	168,3
132 SB	400	29,84	17,28	2400	3600	7200	292,7	304,9	346,0
132 MA	400	39,79	22,88	2400	3600	9600	348,5	360,7	401,0
132 MB	400	54,71	29,52	2400	3600	13200	455,5	467,7	508,0

Motor type	Inverter power supply [V]	Nominal torque [Nm]	Nominal current [I]	Synchronous speed [Rpm]	Maximum speed [Rpm]	Nominal power [W]	Moment of inertia [10 <sup>-4</sup> kgm <sup>2</sup> ] SMR	Moment of inertia [10 <sup>-4</sup> kgm <sup>2</sup> ] BMR	Moment of inertia [10 <sup>-4</sup> kgm <sup>2</sup> ] BAR
<b>4 pole</b>									
<b>56 A</b>	400	0,41	0,96	3600	4000	144	1,75	1,8	
<b>56 B</b>	400	0,65	0,98	3600	4000	216	1,75	1,8	
<b>56 C</b>	400	0,87	1,32	3600	4000	290	1,75	1,8	
<b>63 A</b>	400	0,86	1,08	3600	4000	290	2,32	2,5	
<b>63 B</b>	400	1,27	1,44	3600	4000	430	2,93	3,1	
<b>63 C</b>	400	1,56	1,80	3600	4000	530	3,4	3,5	
<b>63 D</b>	400	2,12	2,52	3600	4000	720	3,68	3,8	
<b>71 A</b>	400	1,71	1,92	3600	4000	600	5,52	5,7	7,20
<b>71 B</b>	400	2,52	2,64	3600	4000	890	6,42	6,6	8,10
<b>71 C</b>	400	3,86	3,96	3600	4000	1320	7,75	7,9	9,43
<b>71 D</b>	400	4,60	4,80	3600	4000	1560	8,24	8,4	9,92
<b>80 A</b>	400	3,75	4,08	3600	4000	1320	10,17	10,6	14,97
<b>80 B</b>	400	5,12	5,28	3600	4000	1800	12,39	12,8	17,19
<b>80 C</b>	400	6,18	6,24	3600	4000	2160	13,5	13,9	18,30
<b>90 SA</b>	400	7,50	6,48	3600	4000	2640	20,02	21,7	26,15
<b>90 LA</b>	400	10,23	8,64	3600	4000	3600	24,40	26,1	30,53
<b>90 LB</b>	400	12,62	10,32	3600	4000	4440	28,44	30,2	34,57
<b>90 LC</b>	400	15,12	12,96	3600	4000	5280	28,44	30,2	34,57
<b>100 LA</b>	400	14,90	12,00	3600	4000	5280	40	44,5	51,14
<b>100 LB</b>	400	20,32	15,60	3600	4000	7200	48,93	53,4	60,0
<b>112 MB</b>	400	27,00	19,44	3600	4000	9600	124,9	133,5	125,7
<b>112 MC</b>	400	36,99	27,60	3600	4000	13200	146,4	155,0	145

### Application

The sectors where they are most used are in automation and packaging (ceramics, conveyor belts, automatic warehouses, etc.). The typical applications are primarily concentrated on machines that use both asynchronous motors driven by inverters and brushless ones, especially in intermittent duty. In the first case (replacement of asynchronous motors), they are indicated in all those applications in which the increase in speed leads to an operation at a frequency that is higher than the basic frequency of the motor with a subsequent decrease in torque. Specifically, the application of these motors allows to keep the gear box reduction ratio unchanged while increasing the frequency without problems. Motors in the "R" series offer more adjustment possibilities (wider frequency range), better dynamic characteristics, similar or less energy consumption with smaller motor size and weight at equal power. Using this product instead of an asynchronous motor makes an increase in transmission ratio necessary if you wish to decrease the size of the motor at equal power. The reduction in size and weight at same power is very evident: this translates into a savings for the customer about the cost of the power transmission (as motor unit + gearbox) and the cost of the machine structure. Using these motors makes also possible to rise the lower motor frequency, moving to a speed range that doesn't need a forced cooling system (an appropriate reduction ratio must be chosen). To maximize the advantages, we recommend using a reduction gear unit rather than a worm gearbox. Replacing brushless motors: these are a valid alternative to servo motors in all applications in which a very strong dynamic is not required and in which a strict interpolation between the two motors is not needed. Compared to a brushless motor, the advantages are a reduction in cost, the absence of dedicated cables and connectors, a reduced maintenance and an extremely simple use that does not require specialized staff.

Definitively this new product allows:

- to think in a new way the process regarding the machine motorization
- to use an asynchronous motor instead of a brushless one
- to have smaller and lighter machines than current ones with equal power
- to have greater speed adjustment intervals
- to have an increased efficiency
- to have a reduced inertia at equal power
- to have a product that is simpler to use
- to have the same accessories as the standard product (encoder, power ventilation, etc.)
- to use any type of commercial inverter in the market
- to eliminate forced ventilation in many cases.

Many industrial sectors have standardized certain types and brands of inverters. "R" series motors were designed and optimized to be extremely versatile and able to maintain the same performance with all major commercial drives This feature means not changing its standard and being able to use the most suitable inverter.

Built-in inverter motors are available with a power range, between 0,37 kW and 15,0 kW while the motor frame is from 71 up to 160. The unit is made up of a high-efficiency 3-phase asynchronous electric motor and a compact frequency inverter placed at the non-drive motor end. The basic construction is totally enclosed, fan cooled (TEFC) and IP 55 protection degree. Built-in inverter motor is able to properly run also under heavy overload conditions thanks to a high thermal reserve; the insulating materials are class F. The frame is made of aluminium alloy up to 132 frame size and of cast iron for above sizes. Shields and flanges are made of aluminium up to 90 frame size and of cast iron up to 160 frame size. The inverter housing is isolated from the motor in order to avoid heat transmission (patented system); the inverter heatsink is self-ventilated. The frequency converter provided is one of the most advanced in design concept as well as the components; used control can be chosen between V/F type (**Frequency Voltage Control**) or SLV type (**Sensorless Vector Control**). Built-in inverter motors are easy to be programmed using only three buttons. Some functions, which automatically set parameters (acceleration/deceleration times, V/f ratio etc.), make the programming easier. On request, motor can be arranged for main Bus fields (Profibus, Interbus-S, Device-Net, etc.). Built-in inverter motors are designed to be real built-in frequency converter motors and not just as a simple assembly of a standard motor with an inverter. The wiring connection is definitely simple to be made. All the adducted features make the built-in inverter motor series high performance with strong structure.

### Application

Built-in inverter motors represent an innovation in the automation field and they give manufacturers, automation designers and machinery users new opportunities and great economical advantages. The ease of installation, the simple structure and the cost-effectiveness of the system are pointed out as follows:

- Overall dimensions are extremely reduced: the couplings are the same of those of a standard motor (special flanges and shafts can be supplied on request);
- protection class is IP 55 as standard (IP 56 is available on request);
- electrical connections are extremely simplified: power and control are totally separated and placed on different terminal boards;
- on request motor can be equipped with built-in EMI filter (class A or B) in order to avoid an external filter application; the motor connection can be carried out through normal power supply cables, as shielded cables are no longer necessary in order to comply with EMC regulations;
- Built-in inverter motors can replace a mechanical speed variator, offering more advantages;
- the system performance is very high in every operating conditions;
- unit switchboard on which SMI motor is installed can be removed or reduced as the inverter has no longer to be housed.

SMI motor represents the solution to the actual needs related to automation systems where actuating and surveying devices can find more places on unit board so to reduce the panel overall dimensions and the wiring costs.

### SMI series

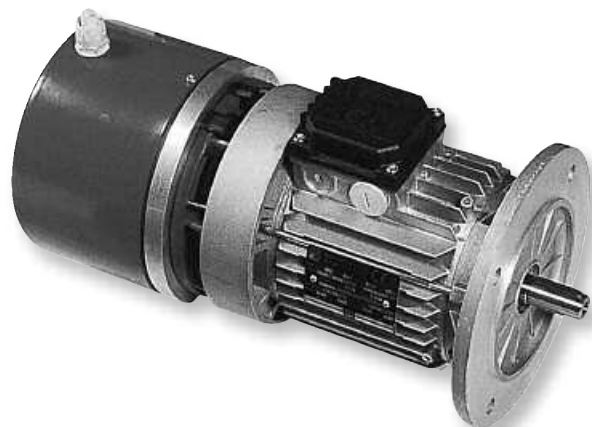

## motors for specific applications

### Motors for wind generators

Brake motors are used in wind generators to rotate the nacelle according to the wind direction (Yaw) and to position the blades based on the wind direction and its intensity (Pitch).

MGM brake motors have been widely used in this sector for years. This type of application requires high reliability, low maintenance and the possibility of an use in special environments (low temperatures, sandy environments, offshore installations).

For this reason, the motors for this application keep certain features that are common to all motors in the BA and BM series and also specific variants, and that can vary depending upon the type of the wind power plant:

- Suitability for operation with inverter
- Various voltage supplies available for both, motor and brake
- Motor power supply separated from the brake ones
- Low moment of inertia
- Possibility to customize the torque curve as need with limitation of the maximum torque
- Protection rating IP54, IP55, IP56, and IP66
- Possibility of installing bi-metallic thermal protectors (PTO) and thermistors (PTC)
- Encoder mounting (upon request)
- Completely closed brake construction (upon request)
- Availability of brake coils with AC or DC supply (built-in rectifier)
- Possibility of installing microswitches upon request to detect the brake release
- Air gap adjustable in an easy way and continuously
- Braking torque adjustable in an easy way and continuously
- Execution for inspection (measurement) of the braking torque (upon request)
- Suitable braking unit to support prolonged slips and at high speed (upon request)
- Low wear of the brake disc linings
- Braking torque stability
- Quick brake intervention
- Locking or non-locking brake release
- Possibility of installing anti-condensation heaters on the motor and on the brake
- Execution for operation for low temperatures (-40° C) available upon request
- Anti-corrosion treatment (upon request)
- Paint depending on the type of installation (for example cycle C5M-H for offshore installations)
- cCSAus certification (upon request)

For the best definition of the type of motor and related variants, we recommend contacting the MGM technical department.

### Motors for automatic industrial doors

BM series motors with certain specific variants are widely used in the industrial door sector. Here below some of the features usually requested for this application:

- Manual brake release with automatic return (non-locking)
- Double output shaft ready for the manual door opening system
- Anti sticking system for the brake disc
- Safety microswitch for manual manoeuvres
- Reduced brake response time
- IP55 protection degree
- Silent execution
- Thermal protectors
- Wide terminal board box
- cCSAus or CCC certification

For the best definition of the type of motor and related variants, we recommend to contact MGM organization.

**BMBM series**

BMBM series consist of asynchronous three phase brake motors with twin DC brakes working independently of each other, starting from 63 up to 315 frame sizes and power range from 0.08 kW up to 132 kW. BMBM series main feature is a very high reliability in those lifting applications where there are high demands of safety and silence. For these reasons BMBM series motors are particularly suitable to be used in TV-cine studios and theatre stages.

The motor brakes in case of power supply failure. The braking action is always secured through a very quick and precise stop assuring a safe and a prompt stop in case of unintentional power supply failure. The brake torque remains the same in both directions of rotation and the braking action occurs without shaft axial sliding. The brake components and assembly are designed with special features to be noiseless during stops. The manual brake release is made up of two levers (one for each brake) so to avoid unwanted starts. It's possible to release the brakes just using one hand.

The two brakes are supplied through independent rectifiers which are positioned in the terminal box. Rectifiers are provided with over-voltage protection device. It's possible to have two types of wirings connection to the rectifier for each brake, in relation to the intervention time required. All BMBM series motors can be driven by inverters. On request, it's possible to have the motor with a built-in encoder or to have the motor ready for the encoder to be easily fitted at customer's place. The brake disc friction material is asbestos free and the brake lining has a high friction factor and is long-lasting. The standard winding insulation class is F. Class H is available upon request. Motor construction type is Totally Enclosed Not Ventilated (TENV) with IP 54 enclosure rating (IP 55 and external cooling are available upon request). BMBM series motors tolerate a high overload level and being not self-cooled have to be used on intermittent duty only.

On request it's possible to provide motors with thermal protection devices (PTO or PTC or KTY), microswitch for brake monitoring (ON/OFF or WEAR function), special double shaft end according to customer design, different types of encoders, different brakes voltage.

Frame is made of die cast aluminum on motors up to 132 frame size and of cast iron on motors from 160 up to 315 frame size. Feet are frame integrated (they are not simply attached to the frame) on IM B3 mounting (foot mounted) and it makes the motor very sturdy since this motors are used in critical applications. Shields and flanges are made of aluminum up to 90 frame size and of cast iron for above sizes.

Frame size (mm)	Standard brake torque (Nm)	Power consumption (W)
63	2 x 3.5	2 x 22
71	2 x 3.5	2 x 22
80	2 x 7.0	2 x 28
90	2 x 14	2 x 34
100	2 x 28	2 x 42
112	2 x 42	2 x 50
132	2 x 70	2 x 64
160	2 x 107	2 x 76
180	2 x 150	2 x 100
200	2 x 250	2 x 140
225	2 x 375	2 x 140
250	2 x 800	2 x 144
280	2 x 800	2 x 144
315	2 x 1000	2 x 144

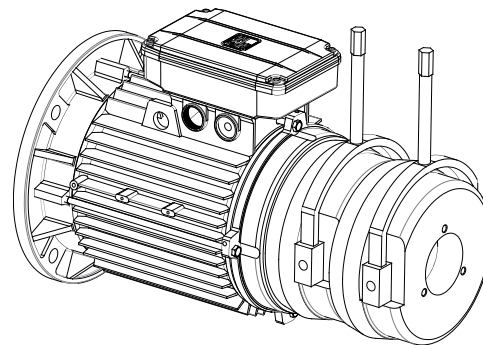

Different brake torques for each of the frame sizes stated here above are available on request. Please contact MGM organization for more information.

# BMBM series dimensions

Size	63	71	80	90S	90L	100	112	132S	132M	160M	160L	180L	200
A	100	112	125	140	140	160	190	216	216	254	254	279	316
B	80	90	100	100	125	140	140	140	178	210	254	279	305
C	40	45	50	56	56	63	70	89	89	108	108	121	133
D	11	14	19	24	24	28	28	38	38	42	42	48	55
d	M4	M5	M6	M8	M8	M10	M10	M12	M12	M16	M16	M16	M20
E	23	30	40	50	50	60	60	80	80	110	110	110	110
Fa	9.5	9.5	11.5	11.5	11.5	14.5	14.5	14.5	14.5	18.5	18.5	18.5	18.5
Fb	M5	M6	M6	M8	M8	M8	M8	M10	M10				
f	4	5	6	8	8	8	8	10	10	12	12	14	16
g	8.5	11	15.5	20	20	24	24	33	33	37	37	42.5	49
H	63	71	80	90	90	100	112	132	132	160	160	180	200
h	4	5	6	7	7	7	7	8	8	8	8	9	10
I	7	7	9	10	10	12	12	12	12	14	14	14	18
L1	166	180	194	207	232	254	262	248	260	314	337	399	424
Ma	115	130	165	165	165	215	215	265	265	300	300	300	350
Mb	75	85	100	115	115	130	130	165	165				
Na	95	110	130	130	130	180	180	230	230	250	250	250	300
Nb	60	70	80	95	95	110	110	130	130				
Oa	3	3.5	3.5	3.5	3.5	4	4	4	4	5	5	5	5
Ob	2.5	2.5	3	3	3	3.5	3.5	3.5	3.5				
Pa	140	160	200	200	200	250	250	300	300	350	350	350	400
Pb	90	105	120	140	140	160	160	200	200				
Q	298	303	342	380	405	456	491	567	605	719	763	832	873
R1	135	135	135	170	170	170	170	180	180	260	260	260	260
S	10	10	12	12	12	14	14	14	14	15	15	15	18
V	7	8.5	9.5	10.5	10.5	13	13.5	18	18	18	18	21	21
W1	111	120	131	148	148	162	176	196	196	267	267	277	277
Y	85	85	105	130	130	150	170	195	195	225	225	258	306
Z1	86	86	86	112	112	112	112	120	120	184	184	184	184

## BMBM series



### BMBM B3

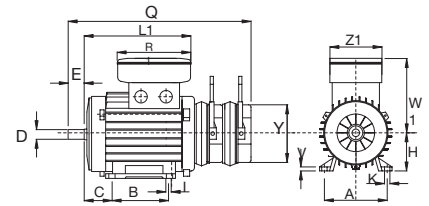

### BMBM B5

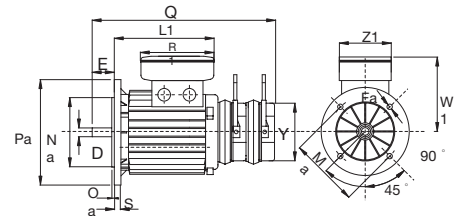

### BMBM B14

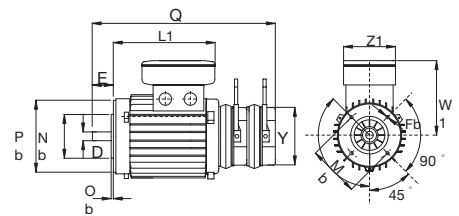

### BMBM 160M/L-180L-200 B3

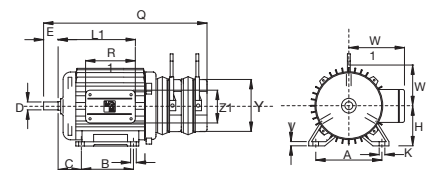

### Shaft End

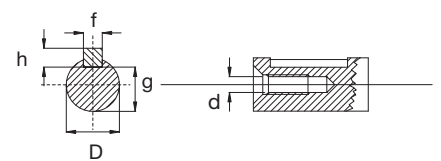

Please contact MGM for further information regarding the dimensions of the motors series BMBM with 225-250-280-315 frame sizes.



**India**



MGM motors can be provided, on request, with BIS certification (standard IS 12615:2018) that is the compulsory certification in India. Certification is required for both standard motors (without brake) and brake motors. Certified motors show the ISI mark on the nameplate.

MGM has certified brake motors in the BAX and BMX series and SMX series (standard motors without brake) with 2, 4, and 6 poles with power between 0.12 kW and 55 kW.

Contact MGM for more information on the available range.

**China**



Upon request, we can provide brake motors with the CCC certification needed for selling the motors in China. Certified motors show the CCC mark on the name plate. To require these motors "With CCC certification" must be specified in the order. For further information, please contact us.

Single speed motors with power:

- $P \leq 2.2$  kW (3000 rpm)
- $P \leq 1.1$  kW (1500 rpm)
- $P \leq 0.75$  kW (1000 rpm)
- $P \leq 0.55$  kW (750 rpm)

must have CCC certification (China Compulsory Certification) in order to be sold in China.

Certification is required for both, standard motors (without brake) and brake motors. You can download the CCC declaration from our website ([www.mgmrestop.com](http://www.mgmrestop.com)). To prove certification, certified motors show the CCC mark on the plate.



MGM has certified brake motors in the BA and BM series with 2, 4, and 6 poles with power up to 1.1 kW. During the order process you must specify "CCC certification".

In China, there is also a regulation regarding motor efficiency. This regulation is applied to motors with powers between 0.75 kW and 375 kW at 2, 4, and 6 poles.

Contact MGM for further information.

**Russia**



MGM motors can be provided, on request, with EAC declaration for the Eurasian Customs Union (Russia, Belarus, Kazakhstan). Please contact the MGM commercial department for further info.

**Australia and New Zealand**

In Australia and New Zealand MEPS (Minimum Energy Performance Standard) fix the minimum efficiency limit on asynchronous three-phase motors starting from 0.73 kW up to 185 kW rated power. This standard doesn't involve two speed motors or S2 duty. Please contact MGM for further details.

MGM motors from 56 up to 315 frame size are individually packed in a box which externally reports the motor identification data. The table below shows the boxes dimensions for each size. Motors with frame size 160 up to 225 are fixed down to pallets with squared timbers. Pallets have EURO overall dimensions (120 x 80 cm). The boxes are marked with stickers providing information about the final destination, customer code number and address and production lot number. Additional protective materials as cardboard and shrink film around the pallet are used for sea and air shipments.



Motor size	Depth (cm)	Width (cm)	Height (cm)
Brake motor frame size 56 mm	38	19	22
Brake motor frame size 63 mm	38	19	22
Brake motor frame size 71 mm	38	19	22
Brake motor frame size 80 mm	49	23	27
Brake motor frame size 90 mm	49	23	27
Brake motor frame size 100 mm	54	29	35
Brake motor frame size 112 mm	54	29	35
Brake motor frame size 132 mm	69	35	42
Brake motor frame size 160 mm*	93	63	52
Brake motor frame size 180 mm*	93	63	52
Brake motor frame size 200 mm*	93	63	52
Brake motor frame size 225 mm	120	80	70
Brake motor frame size 250-280 mm	135	80	80

BAF-BAPV 71 serie-motors are packed into boxes with a dimension of 49 x 23 x 27 cm.

Motors highlighted with \* can be delivered either inside a box or fixed on the pallet.

On request for a high quantity batch of the same motor size it's possible to pack the motors directly in a single big box (MULTIPACK). Motors are arranged in carton layers in order to protect goods integrity. The drawing here below shows the box overall dimension while the chart shows the batch quantity that can be inserted in each MULTIPACK box according to the frame size.

The stated quantity has to be considered an approximate quantity as it changes with the required motor mounting (B3, B5, B14 etc.).

Frame Size	Quantity
56-63	80
71	40
80	30
90	20

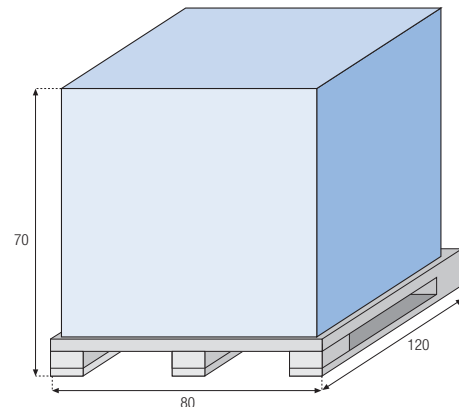

### Terms and Conditions of Sale and warranty

All goods manufactured or supplied by MGM motori elettrici SpA shall be subject to MGM terms and conditions of sale and warranty listed on the MGM internet site [www.mgmrestop.com](http://www.mgmrestop.com)

The table below shows the available main special features and the options for MGM motors. Letter S stands for “Standard”, letter R stands for “on Request” and letter N stands for “unavailable”.

Ref.	Description	BM	BA
1	Non-standard flange	R	R
2	Special motor shaft as per drawing	R	R
3	Motors with feet and flange (IM B35 and IM B34 with corresponding vertical mounting)	R	R
4	Balancing for reduced or special vibration level	R	R
5	Separate brake supply (two different terminal boards)	<sup>1</sup>	R
6	IP 55 or IP 56 Enclosure rating (protection degree)	R	R
7	Special motor/brake voltage or frequency supply	R	R
8	Motor Insulation Class H	R	R
9	Brake torque and/or air gap pre-adjustment to desired value	R	R
10	CSA approval 	R	R
11	CCC approval 	R	R
12	Special pole motors (not listed in this catalogue)	R	R
13	Standstill heating	R	R
14	Bimetallic thermal protectors PTO	R	R
15	Thermistors PTC	R	R
16	Tropicalization treatment of motor windings	R	R
17	Over-voltage safety cutout (RC04 and RC10)	R	R
18	Terminal box on the right (left) side for IM B3 (BA 80-132)	N	R
19	Double shaft end	<sup>2</sup>	R
20	Test certificate	R	R
21	Rain roof (BM), special fan cover for outside vertical mounting	R	N
22	Brake cover (BA), special brake cover for outside vertical mounting	N	R
23	Precise tolerance class	R	R
24	Fan cover for textile environment	<sup>4</sup>	S
25	Motor with built-in encoder or tachogenerator	<sup>2</sup>	R
26	Motor arranged for manual rotation (shaft fitted with hexagonal hole at non-drive end)	<sup>3</sup>	S
27	Special finishing (marine environment, washdown applications)	R	R
28	Manual brake release screws	<sup>2</sup>	N
29	Manual return brake release lever	R	R
30	T key for manual shaft rotation	R	R
31	Stainless steel tie rods, bolts, nuts and screws	R	R
32	Forced cooling motor (SV, AV series)	R	R
33	Motor with additional cable gland holes	R	R
34	Zinc plated brake surfaces	R	R
35	Drain holes	R	R
36	Stainless steel friction surface	R	R
37	Brake release microswitch	R	R
38	Microswitch detector of brake disc wear	R	R

**1**

Double terminal board box for brake separate supply is provided as standard on BM and BA two speed motors while it's on request only on single speed motors.

**2**

Brake manual release screw is not provided as standard on BA motors with double shaft end or with encoder or tachogenerator.

**3**

Motor with frame size up to 132 are fitted as standard with hexagonal hole at Non-Drive end. The hexagonal hole is available on request on motors with frame size 160 and above.

**4**

BA series motors don't need the fan cover for textile environment.

To clearly identify a spare part it's necessary to provide the item number (shown on the drawing below), the motor type, the rated voltage and frequency supply for electric parts such as the stator, the brake coil and the rectifier.

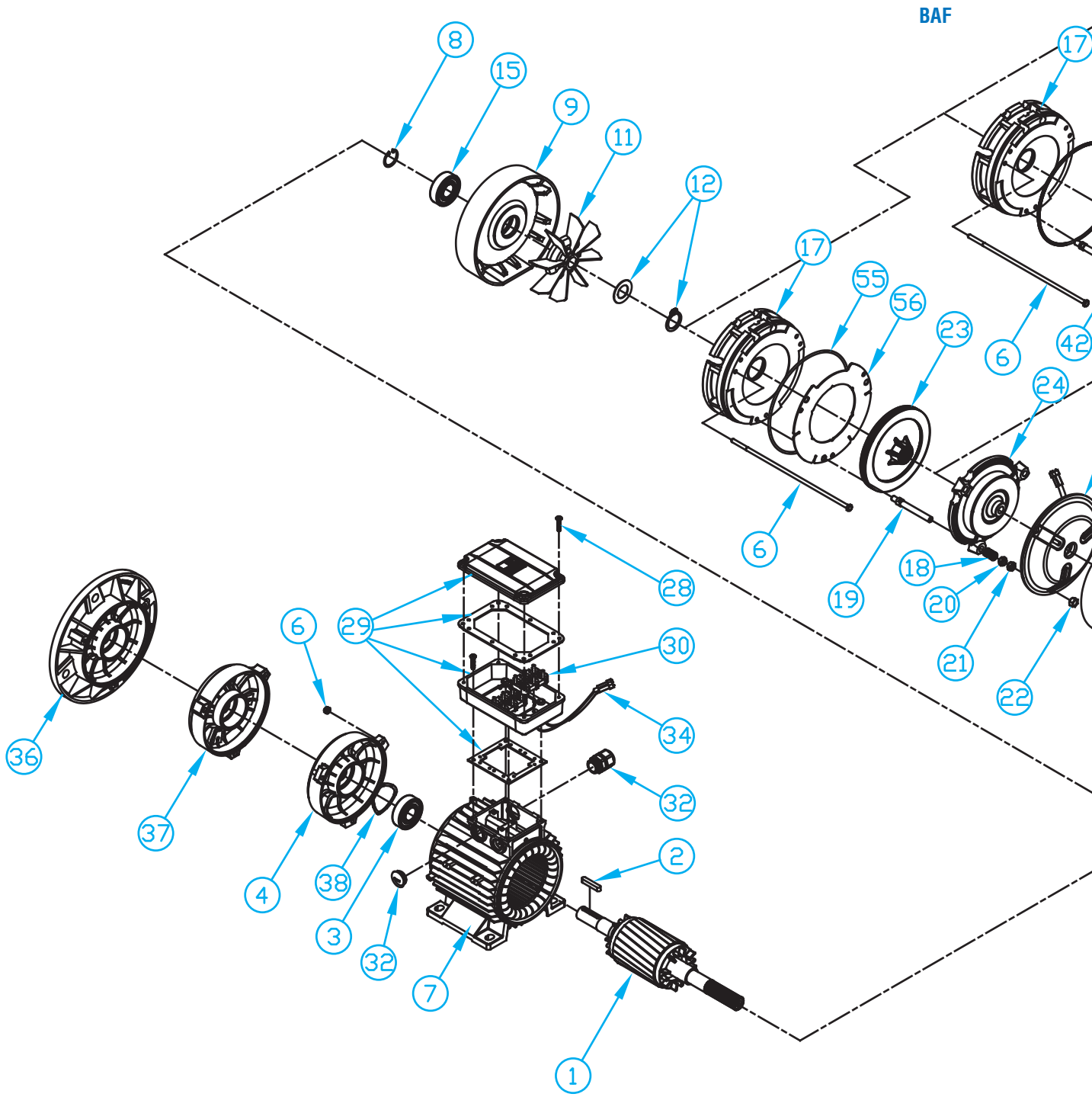

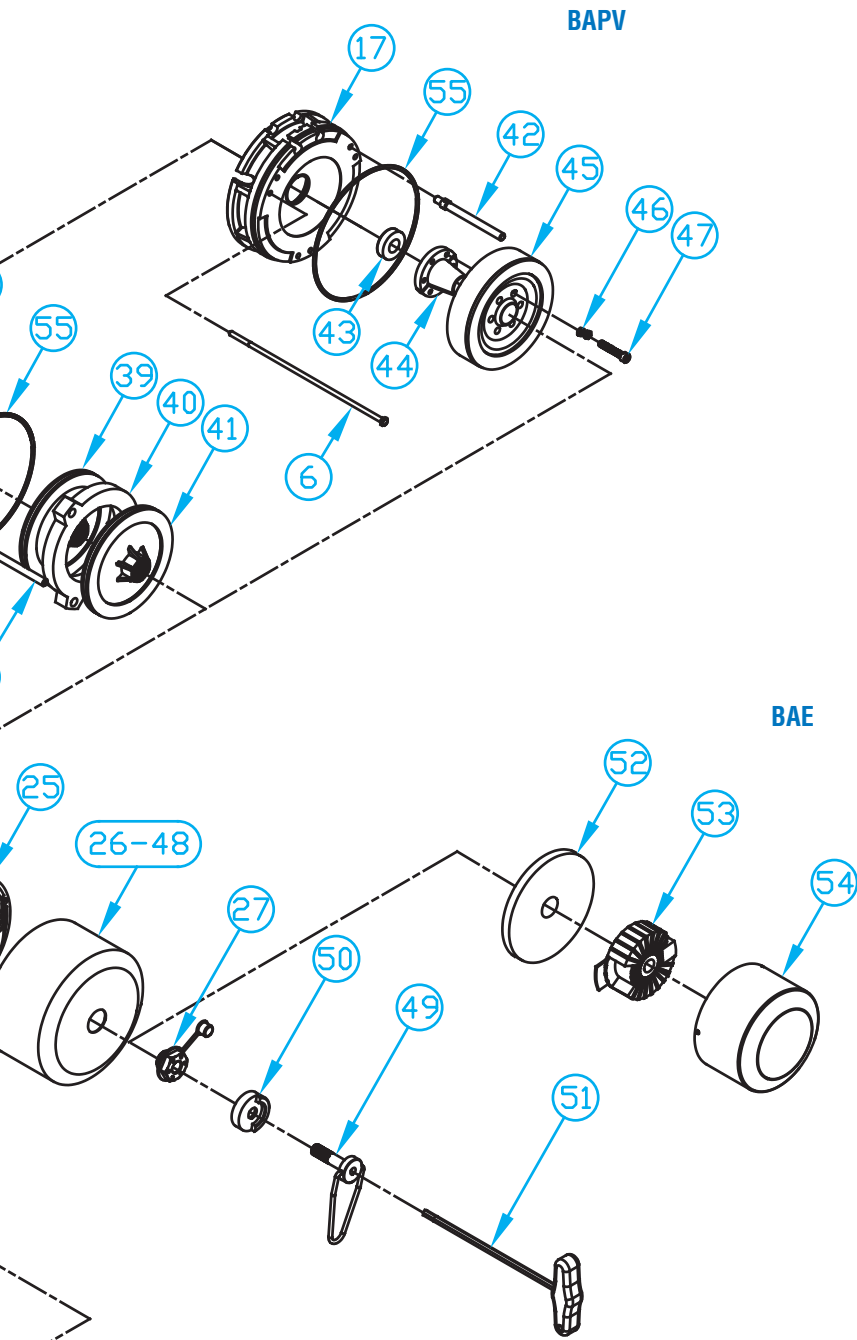

Complete Rotor	1
Key	2
Bearing Drive End side	3
Endshield Drive End (front cover)	4
Tie rod assembly	6
Stator frame	7
Circlip	8
Endshield Brake Side (rear cover)	9
Fan	11
Fan fixing accessories	12
Bearing Non Drive Side	15
Brake Friction Surface	17
Spring	18
Brake adjuster	19
Brake torque adjuster locknut	20
Air gap adjusting nut	21
Brake coil locknut	22
Brake Disc	23
Brake Moving Element	24
Brake Coil	25
Brake Cover (BA)	26
Hexagonal Rear Nut (socket head nut)	27
Terminal Box Screws	28
Terminal Box (single or double)	29
Terminal Board	30
Cable Gland	32
Brake Coil Connection Cables	34
Flange B5 (Flange Mounting)	36
Flange B14 (Face Mounting)	37
Elastic Washer	38
Brake Disc (BAF)	39
Additional Brake surface (BAF)	40
Additional Brake Disc (BAF)	41
Long Brake Adjuster (BAPV-BAF)	42
Spacer (BAPV)	43
Taper Bush (BAPV)	44
Flywheel (BAPV)	45
Elastic Washer (BAPV)	46
Taper bush fixing screws (BAPV)	47
Brake Cover (BAPV-BAF)	48
Brake Release Screw	49
Fulcrum Hub for brake release (on request only)	50
Allen key for manual shaft rotation (on request only)	51
Encoder fixing plate (BAE)	52
Encoder (BAE)	53
Encoder protection cover (BAE)	54
Brake assembly O-Ring	55
Stainless steel plate (on request)	56
Hand brake release kit Unlocking type (not shown on the drawing)	//

**spare parts**

To clearly identify a spare part it's necessary to provide the item number (shown on the drawing below), the motor type, the rated voltage and frequency supply for electric parts such as the stator, the brake coil and the rectifier.

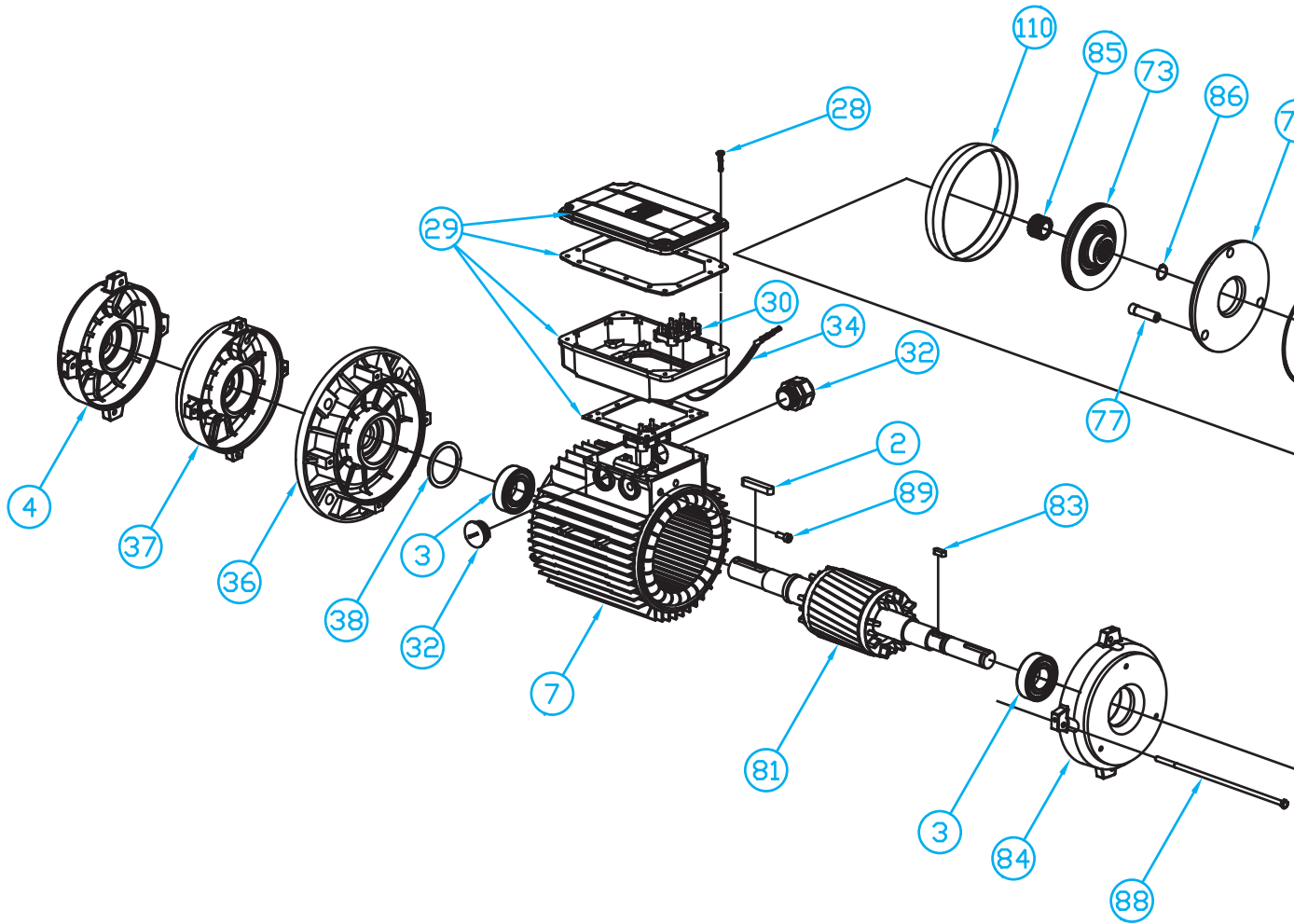

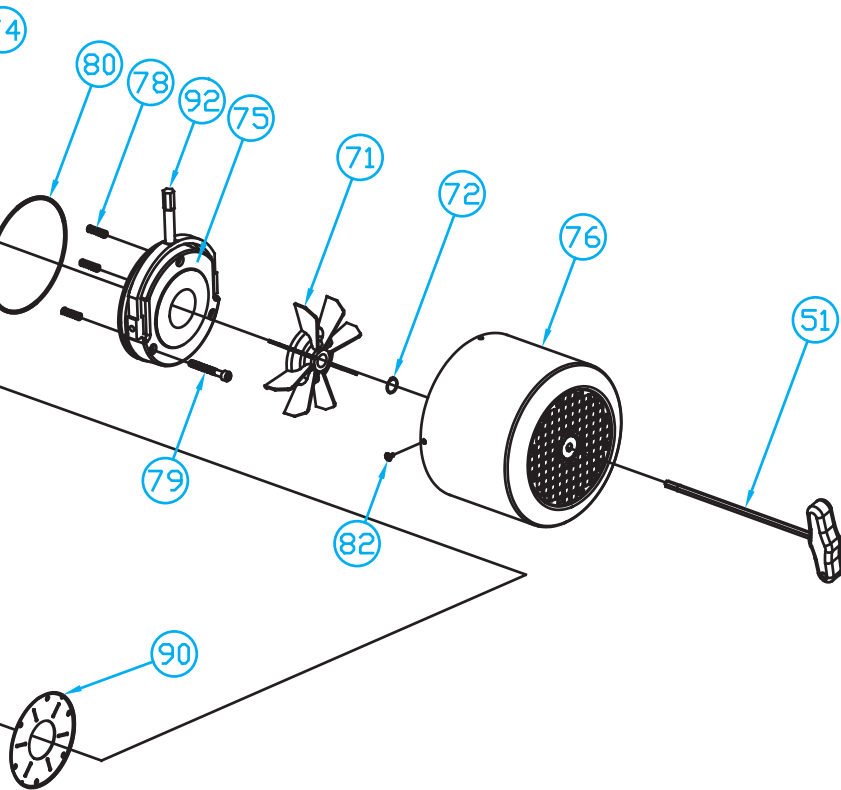

Key	2
Bearing Drive End Side	3
Endshield Drive End	4
Stator Frame	7
Terminal Box screws	28
Terminal Box (single or double)	30
Cable Gland	32
Flange B5 (Flange Mounting)	38
Flange B14 (Face Mounting)	37
Elastic washer	38
Allen key for manual shaft rotation (on request only)	51
Fan	71
Fan Snap Ring	72
Brake Disc	73
Brake Moving Element	74
Brake Coil	75
Fan Cover	76
Connecting Screw	77
Adjustable or Fixed Springs	78
Brake Fixing Screw	79
Brake Assembly O-ring (on certain motor types only)	80
Complete Rotor	81
Fan Cover Screw	82
Brake Assembly Key (on certain motor types only)	83
Endshield Brake Side (rear cover)	84
Hub (on certain motor types only)	85
Fixing Hub Snap Ring (on certain motor types only)	86
Terminal Box with built-in rectifier (in alternative double terminal board box; refer to page 13 for the rectifier type)	87
Tie Rod	88
Rubber Sleeve	89
Stainless steel plate (only for some types of motors)	90
Flywheel BMPV (not represented represented on the drawing)	91
Manual brake lever kit (on request)	92
Brake protective ring (on certain motor types only)	110



From our website ([www.mgmrestop.com](http://www.mgmrestop.com)) in the section DOCUMENTATION you can download documents, images or technical support videos:

- 2D and 3D motors drawings
- technical data sheets
- wirings
- use and maintenance manuals
- videos showing how to carry out the main maintenance work on the motors (also visible on smartphone or tablet)
- photos of spare parts to better identify them
- certificates (cCSAus, CCC etc)
- catalogues
- technical documentation of various kind

COD. RIF. A05E2020





Serravalle P.se - Italy



Assago - Italy



Montreal - Canada



Detroit - USA



Chennai - India



Izmir - Turkey

**MGM Motori Elettrici SpA** was founded in 1947. Right from the start the company specialised in the production of electrical brake motors, becoming one of the leader companies in the world in this industry.

In Italy MGM has the main production plant in Serravalle Pistoiese and a warehouse with sales offices in Assago (Milan).

MGM also has plants in Montreal (Canada), Detroit (USA), Chennai (India) and Izmir (Turkey). Around the world, MGM is present in more than 70 countries with its own structures for sales and assistance.

Anywhere in the world, you can hardly see, wear, or use anything which does not have at least one component produced by an MGM brake motor.

**We are present in more than 70 countries in the world with sales point and after sales points:**

Algeria, Argentina, Armenia, Australia, Austria, Azerbaijan, Bangladesh, Belgium, Bolivia, Bosnia, Brazil, Bulgaria, Canada, Chile, China, Colombia, Croatia, Cyprus, Czech Republic, Denmark, Egypt, Estonia, Finland, France, Germany, Great Britain, Greece, Hungary, India, Indonesia, Ireland, Israel, Japan, Jordan, Kosovo, Latvia, Libya, Lithuania, Malaysia, Malta, Mexico, Montenegro, Morocco, Netherlands, North Macedonia, Norway, Pakistan, Peru, Philippines, Poland, Portugal, Romania, Russia, Saudi Arabia, Serbia, Singapore, Slovakia, Slovenia, South Africa, South Korea, Spain, Sweden, Switzerland, Taiwan, Thailand, Tunisia, Turkey, Ukraine, United Arab Emirates, United States, Venezuela, Vietnam.



## MGM Electric Motors

### Italy

#### Head office and production

S/R 435 Lucchese Km 31  
I - 51030 Serravalle Pistoiese (PT) - ITALY  
Tel. +39 0573 91511 (r.a.)  
Fax +39 0573 518138  
Web [www.mgmrestop.com](http://www.mgmrestop.com)  
E-mail [mgm@mgmrestop.com](mailto:mgm@mgmrestop.com)



#### North Italy branch office

I - 20090 Assago Milano - Via Fermi, 44  
Tel. +39 02 48843593 - Fax +39 02 48842837

### Canada

#### Head office and production

3600 F.X. Tessier, Unit # 140  
Vaudreuil, Quebec J7V 5V5 - CANADA  
Sales (877) 355 4343  
Tel. +1 (514) 355 4343 - Fax +1 (514) 355 5199  
Web [www.mgmelectricmotors.com](http://www.mgmelectricmotors.com)  
E-mail [info@mgmelectricmotors.com](mailto:info@mgmelectricmotors.com)

### USA

#### Head office

269 Executive Drive  
Troy, MI 48083 - USA  
Tel. +1 (248) 987 6572 - Fax +1 (248) 987 6569  
Web [www.mgmelectricmotors.com](http://www.mgmelectricmotors.com)  
E-mail [infousa@mgmelectricmotors.com](mailto:infousa@mgmelectricmotors.com)

### India

#### Head office and production

Door No. 68, Indus Valley's Logistic Park  
Unit 3, Mel Ayanambakkam, Vellala Street  
Chennai 600 095, Tamil Nadu - INDIA  
Tel. +91 44 64627008  
Web [www.mgmvarvelindia.com](http://www.mgmvarvelindia.com)  
E-mail [info@mgmvarvelindia.com](mailto:info@mgmvarvelindia.com)

### Turkey

#### Head office and production

İTOB Organize Sanayi Bölgesi,  
Ekrem Demirtaş Cad. No: 28 Menderes  
İzmir - TURKEY  
Tel. +90 232 799 0347 - Fax +90 232 799 0348  
Web [www.mgmmotor.com.tr](http://www.mgmmotor.com.tr)  
E-mail [info@mgmmotor.com.tr](mailto:info@mgmmotor.com.tr)